

# ***series 50***

*Minitransporter*



*Ed. 0*



**USER'S MANUAL AND MAINTENANCE**



**This manual should always be readily available so that the machine operator may consult it immediately, and it must be saved for the entire duration of the machine's life.**

© 2006 – The entire or partial reproduction and/or divulging of this document is prohibited in any form without the written consent of the manufacturing company. The editing of the text, the illustrations, and the paginations were realized by "Cormidi s.r.l." The information and technical data were furnished, checked and validated by the Cormidi Technical Office. The illustrations and technical data included in this manual are non binding: **the manufacturer reserves the right to carry out eventual modifications to its product without notice.**

**CORMIDI**  
leadinginnovation

**CORMIDI srl**

Via Seude Loc. Fonte  
84069 Roccadaspide (SA)

☎ 0828 943689 Fax 0828 943963

💻 [www.cormidi.com](http://www.cormidi.com) [info@cormidi.com](mailto:info@cormidi.com)

## INTRODUCTION

---

*Dear Customer,*  
*We would like to take this opportunity to thank you for your confidence in us shown by purchasing a CORMIDI Minitransporter. This product was designed and constructed for longevity and to be used with maximum reliability.*

*It is, however, **absolutely necessary** to read this manual carefully in which the procedure for optimum use of the equipment is described: improper use may provoke harm to oneself and cause injury to persons and/or to one's health.*

*Therefore, always keep this manual within easy reach so that it may be consulted at any time, before, during, and after use. If the machine is resold, do not forget to give it to the new owner in that inside there is the **EC compliance certificate**.*

*We would like to remind you that the illustrations contained in the manual correspond for the most part to the base model and that our models are regularly*

*improved and perfected with the goal of allowing our customers to enjoy the maximum benefits of innovations in technology: for this reason the characteristics and the information contained in the present manual may have been varied recently. We ask you to contact us in case you should encounter difficulty.*

*Remember for supplementary information you can always contact your sales representative/dealer, or you can contact us directly by telephone or by email at [info@cormidi.com](mailto:info@cormidi.com). If there is any doubt, it is better to ask rather than proceed on your own.*

*We leave you to your perusal of the manual and enjoyment of your machine!*

*Cordially,*

*Staff CORMIDI Srl*

---

## 1. GENERAL INFORMATION

---

### 1.1. WARRANTY

---

Your machine is guaranteed for 12 months from the date of its delivery and includes the substitution of anything in particular that has resulted as, in the opinion of our Technical Office, affected by construction defects.

Any defect in particular that was not caused by the manufacturer, parts used in/on terrain surfaces, and breakdowns caused by incompetence or carelessness, including fueling, are excluded from the guarantee.

The motor, instead, is covered under the manufacturer of the motor's own warranty according to the foreseen conditions and terms.

The guarantee immediately expires if the machine is utilized for uses different from those foreseen by the Manufacturer, if it is damaged by the use of unauthorized accessories or if it is repaired using unsuitable parts.

With the machine a Certificate of Warranty was supplied which outlines the norms which regulate the service of assistance under warranty. We highly recommend reading the **warranty form** to fully

understand the various rights and responsibilities. Collaborate with your sales representative when filling out the form and make sure it is filled out correctly, in that the text and the other formalities (shipment within the time limit, etc.) represent the legal base for the warranty on the machine.

### 1.2. GOAL OF THE MANUAL

---

This manual has been drawn up by the manufacturer and is an integral part of the machine: it was written in Italian, the native language of the manufacturer.

The information contained herewithin is addressed to expert operators, equipped with specific knowledge and competence in the sector of use. The manual defines the objectives for which the machine was designed and constructed.

To avoid incorrect manoeuvres that risk accident, it is important to read this manual particularly before the first use to familiarize oneself with the principal commands and their functions.

A constant observance of the information

guarantees safety, economy of use, and a longer functional duration of the machine.

To give a higher prominence to the sections of the text which must not be

ignored, they have been highlighted in bold and preceded with symbols illustrated and defined following here:



**READ CAREFULLY:** invites a careful and scrupulous reading of the manual before carrying out the operations described.



**DANGER:** indicate imminently dangerous situations that can provoke serious injury or death if the instructions are not followed.

On the machine potential dangers have been indicated with a sticker characterized by a *red band with white text*.



**WARNING:** indicates a potentially dangerous situation that can provoke serious injury or death if the instructions are not followed.

On the machine the warnings are indicated with stickers characterized by an *orange band with black text*.



**CAUTION:** indicates a potentially dangerous situation that can provoke injury or damage to the machine if the instructions are not followed.

On the machine situations requiring caution are indicated by stickers characterized by a *yellow band with black text*.



**PROHIBITED:** prohibitions that must be observed by all persons who interact directly and/or indirectly with the machine so that risks may be limited.

### 1.3. MACHINE DESCRIPTION

---

The Series 50 machines are auto-unloading tracked vehicles that are compact and equipped with a body, designed and manufactured for the exclusive use of transporting inert materials or agricultural products.



**READ CAREFULLY:** Determine the type of motor that has been installed in your machine accurately, and read its manual to familiarize yourself with it.

To satisfy the various requirements of the market, the machine may be equipped with motors that have similar power but that have different brand names and

characteristics.

#### 1.4. SAFETY INFORMATION



**READ CAREFULLY:** The information contained here is essential for your safety and for that of your co-workers!

During the production of this machine, every possible measure was taken to make your work safer. Simple prudence, however, is essential: there is no better rule to prevent accidents.



**WARNING:** The machine must always be operated by a competent and well-trained operator.

- ☞ Carefully read the information before using the machine or before performing maintenance and/or repairs.
- ☞ A few minutes of your time spent reading this manual will save you time and effort later on a.
- ☞ Carefully read the warnings and information written on the signs on the machine and immediately substitute missing or illegible ones. **Respect all regulations contained in these.**
- ☞ The machine was made exclusively for the

transportation of inert materials. Any other use is prohibited.



**PROHIBITED:** It is strictly prohibited to use this machine for the transport of persons and/or animals.



**PROHIBITED:** It is strictly prohibited to use this machine to tow other machines, vehicles, and/or devices, not even temporarily or in an emergency situation.

- ☞ The machine constitutes a work instrument: always respect the national regulations, especially those relative to safety at the place of work.



**REQUIRED:** Always wear suitable work clothes and above all suitable work shoes diligently. Always use protective hearing devices.



**WARNING:** Never wear large or fly-away clothes (scarves, ties) that could easily get caught in the moving parts.

- ☞ It is always advisable to have a first aid kit close at hand.
- ☞ Before turning on the motor, always be sure that there are not any people, animals, or things that

could be an obstacle in the work area.



**DANGER:** Never use the machine inside enclosed areas because the gasses emitted by the exhaust are lethal.



**REQUIRED:** Carry out the disposal of oils, minerals, and harmful products with respect for the environment and in accordance with the current norms.

☞ Every intervention for cleaning, tuning, and/or maintenance must be done under good environmental conditions and with adequate light, and always with the motor turned off.



**DANGER:** Never refuel the vehicle when the motor is on or hot, in the proximity of flames or while smoking. Always keep the machine cleaned of lubricant and/or combustible residues.

☞ Pay careful attention to not come into contact with the overheated parts of the motor.



**PROHIBITED:** It is strictly prohibited to remove protection and safety devices with which the machine is equipped.

☞ Avoid working under unsuitable physical conditions

or when you are very tired: in these cases interrupt your work.



**DANGER:** While working always be sure that the terrain has the required consistency and avoid working on the edge of embankments, ditches, or ravines or on excessively steep or uneven terrain.

☞ When putting away the machine take all precautions so that it might not be moved or turned on by incompetent or incapable persons.



**CAUTION:** Never leave the tool unattended while the motor is on, not even temporarily: when you leave the area, turn off the motor of the machine and put on the parking brake!



**DANGER:** Never let children play with the machine, not even if it is turned off!

---

## 1.5. MACHINE AND MANUFACTURER IDENTIFICATION

---

The data which identifies the machine and the manufacturer are listed on the aluminium plate that is affixed on the dashboard of the machine. The frame number is stamped to the left posterior part of the frame (see fig. 1).

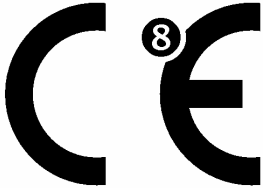
Modello	2	<input type="text"/>	 <p><b>CORMIDI srl</b>          Via Seude - Loc. Fonte          84069 ROCCADASPIDE (SA) ITAL          0828 943 689 Fax 0828 943 963          www.cormidi.com info@cormidi.com</p>
Matricola	3	<input type="text"/>	
Portata Kg	4	<input type="text"/>	
Massa Kg	5	<input type="text"/>	
kW	6	<input type="text"/>	
Anno	7	<input type="text"/>	

C1094.14.00

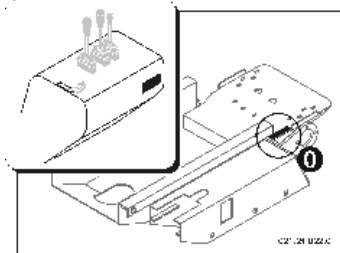

fig. 1 – Identification plate (cod. C1094.14.00)

1	Manufacturer
2	Machine Type
3	Serial Number
4	Load capacity KG
5	Machine Mass KG
6	Engine Power KW
7	Fabrication Year
8	EC Brand
0	Frame number

## 1.6. SAFETY DEVICES



**PROHIBITED:** it is strictly prohibited to use the machine with its safety devices and protection removed, blocked, or in any way made non functional.



**WARNING:** Before beginning work, verify the working order of the safety devices and substitute any worn-out and/or broken parts immediately.

### 1.6.1. BLOCKING THE BODY

The machine is equipped with a device to block the body in the raised position and to prevent it from lowering accidentally.

Before carrying out any repair maintenance work with the body raised, always block the piston following this procedure (see fig. 2):

- raise the body;
- turn off the motor;
- remove device “A” from its slot by unscrewing wheel “B”;
- insert the hole of the bar on the piston of the hydraulic jack;
- turn the bar and position it so that it is parallel to the piston;
- slowly lower the unit **with the motor off** until the correct fit of the device is.

Afterwards remove the device and put it back in its slot.

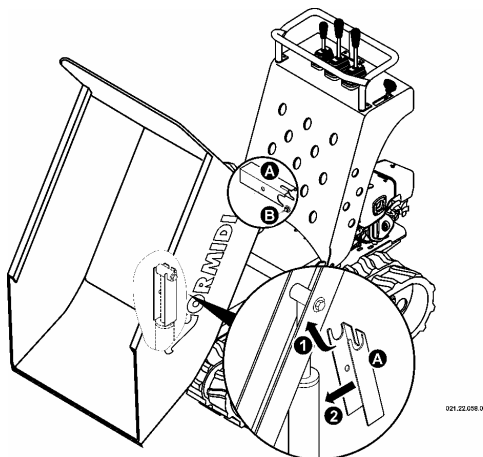

fig. 2 – Safety devices

### 1.7. ACCESSORIES

---

The machine is furnished with equipment for normal maintenance operations.



**READ CAREFULLY:** Read the instructions and the mode of use for the accessories that have been installed on your machine carefully. Refer to the instruction manual that was provided with them.

### 1.8. SAFETY TAGS

---



**READ CAREFULLY:** During the design phase everything possible was done to prevent eventual risks: where it was technically impossible, specific pictograms were resorted to in order to highlight eventual potential and imminent risks. Specific adhesive tags were made with signals and descriptions associated with pictograms to give a higher importance to possible dangers, in accordance with norms UNI 9244-95 (E).



**PROHIBITED:** it is strictly prohibited to remove the stickers and the safety plates which the machine is equipped with: immediately substitute deteriorated and/or illegible ones.



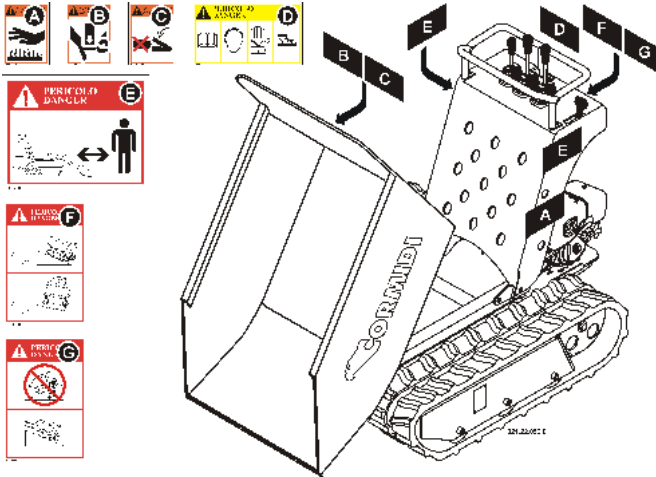

fig. 3 – Tag Safety Position

### 1.8.1. HOT SURFACES

Invites caution in that there is a risk of burning because of the nearness to the hot surface.



fig. 4 (cod. C1094.07.00)

### 1.8.2. CRUSHING

Tags which indicate a potential risk of crushing that may cause very serious injury or death.



fig. 5 (cod. C1094.09.00)

### 1.8.3. CUTTING

Tags which indicate a potential risk of cutting that may cause very serious injury or death.



fig. 6 (cod. C1094.09.00)

### 1.8.4. SAFETY DISTANCE

Tags which alert one to a serious danger of coming near and standing in the field of action of the machine in that there is an imminent risk of danger to self.



fig. 7 (cod. C1094.02.00)

### 1.8.5. PROCEDURE FOR CAUTION

This adhesive which invites caution reminds one to adopt all anti-injury precautions, above all regarding the use of protective devices and individual prevention.



fig. 8 (cod. C1094.04.00)

The meaning of the pictograms is the following:

- Read the manual before turning the machine on for the first time, each time an operator is changed, and in any case in which doubt is raised as to how the machine functions;
- Wear a headset which protects hearing or another device of this type;
- Wear protective gloves of the prescribed type;
- Wear injury-preventive shoes of the prescribed type.

### 1.8.6. MAXIMUM SLOPES

Completely avoid working on



fig. 9 (cod. C1094.01.00)

terrains that have latitudinal slopes of more than  $10^\circ$  and longitudinal slopes of more than  $20^\circ$  to avoid the possibility of overturning with serious consequences for the safety of the operator. In every case, but especially in the case of slopes, it is important that the terrain is solid and stable.

### 1.8.7. PROCEDURE FOR ADDRESSING SLOPES

Sign which indicates in what way one must address the downhill and uphill slopes to avoid serious consequences for the operator and for the machine in that there is the potential danger of overturning.



fig. 10 (cod. C1094.06.00)

### 1.9. ADMISSIBLE SLOPES

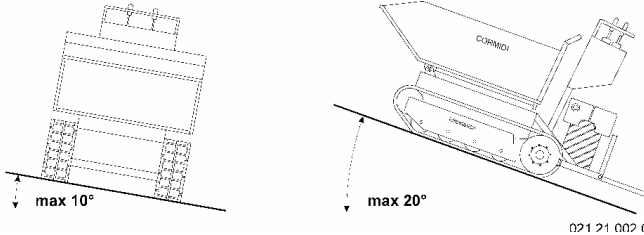

fig. 11 – Maximum admissible slopes

In figure 11 the maximum values for the latitudinal and longitudinal slopes of the terrain are shown on which it is possible to work. These conditions must never be surpassed to avoid the risk of overturning.



**DANGER:** Always avoid working on terrain with slopes that are greater than those prescribed to avoid the possibility of overturning with possible serious consequences for the safety of the operator.

Always be sure that the terrain upon which you are working or travelling is solid and stable: avoid travelling on excessively soft and/or muddy terrain that can hide snares and throw the machine off balance, or on loose material that has accumulated that can shift under the weight of the machine.

### 1.10. DIMENSIONS

Length		1500 mm
Width		700 mm
Wheel Track		520 mm
Height	Min	1040 mm
	Max	2585 mm

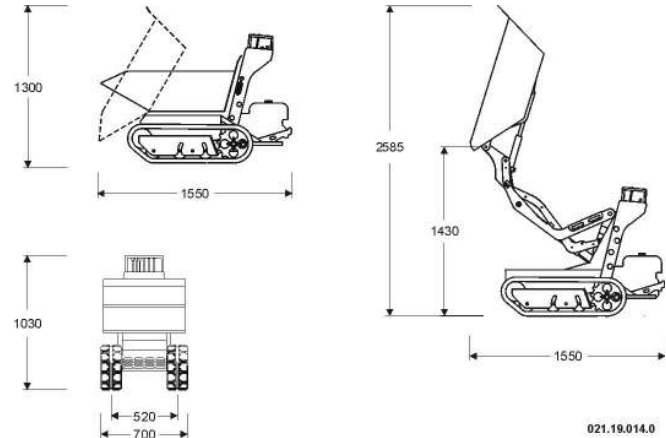

fig. 12 – Dimensions

### 1.11. TECHNICAL DATA

Model	Dumper			Hi-Tip	
Typo	6.50			6.50	
Mass [kg]	280	290		385	385
Power [kW] - (cv)	4,8 (6,5)	3,7 (5)	5,5 (7,5)	4,8 (6,5)	5,5 (7,5)
Max Speed [m/s] - (km/h)	0,8 (2,9)	0,8 (2,9)	1,1 (4)	1,1 (4)	
Load Capacity [kg]	500			500	
Start-up	Pull-start				
Accelerator	Manual command lever				
Transmission	Hydrostatic				
Battery	12V - 40Ah with negative at mass				

## 2. COMMANDS

### 2.1. HYDRAULIC TIPPING VERSION

#### ***The left drive lever***

The left-hand drive lever controls the left track.

The command levers control the rotation of the tracks through a hydraulic feed of the hydraulic motors.

The command levers are active only when the motor is turned on.

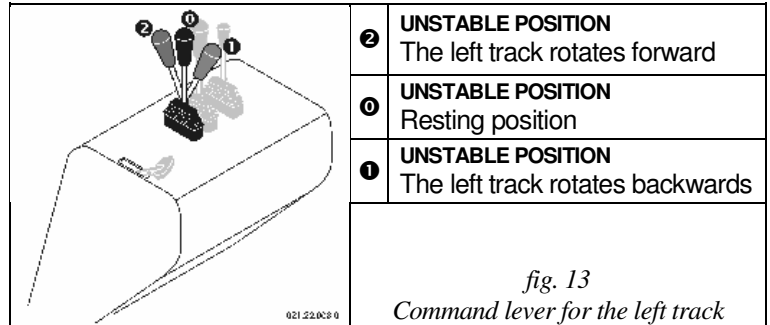

#### ***The right drive lever***

The right-hand drive lever controls the right track.

The command levers control the rotation of the tracks through a hydraulic feed of the hydraulic motors.

The command levers are active only when the motor is turned on.

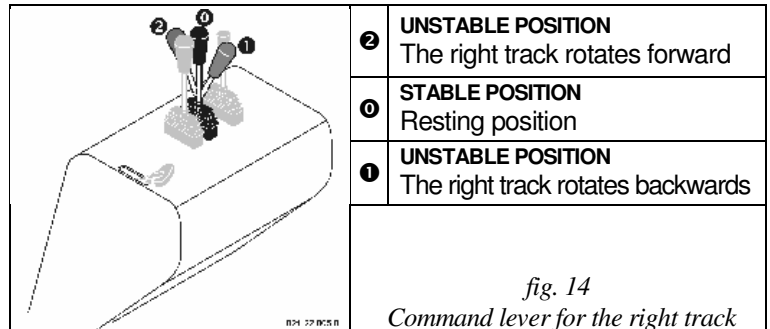

### Command Lever for the Body

The command lever for the body activates the hydraulic jack that provokes the overturning of the body.

This position ② can only be used with the motor turned on, while this position ① can also be used when the motor is turned off.

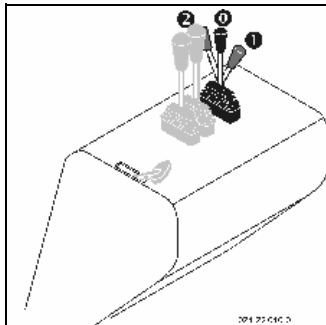

②	<b>UNSTABLE POSITION</b> The body overturns
①	<b>STABLE POSITION</b> Resting position
①	<b>UNSTABLE POSITION</b> The body lowers
<p><i>fig. 15</i> <i>Command lever for the body</i></p>	

### Accelerator Command

Allows variations in the rotation regimen of the motor to obtain the required power.

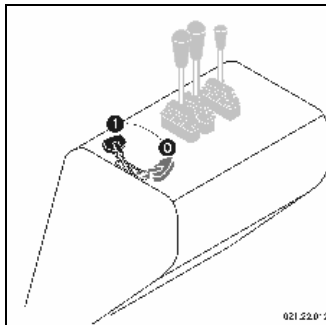

①	<b>STABLE POSITION</b> Minimum regimen
...	<b>STABLE POSITION</b> Intermediate regimens
①	<b>STABLE POSITION</b> Maximum regimen
<p><i>fig. 16</i> <i>Command for the accelerator</i></p>	

**2.2. TWIN VERSION (DOUBLE SPEED)**

***The left drive lever***

The left-hand drive lever controls the left track.

The command levers control the rotation of the tracks through a hydraulic feed of the hydraulic motors.

The command levers are active only when the motor is turned on.

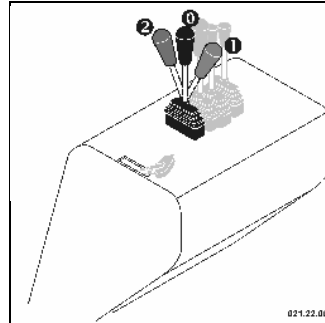

<b>2</b>	<b>UNSTABLE POSITION</b> The left track rotates forward
<b>0</b>	<b>UNSTABLE POSITION</b> Resting position
<b>1</b>	<b>UNSTABLE POSITION</b> The left track rotates backwards
<p><i>fig. 17</i> <i>Command lever for the left track</i></p>	

***The right drive lever***

The right-hand drive lever controls the right track.

The command levers control the rotation of the tracks through a hydraulic feed of the hydraulic motors.

The command levers are active only when the motor is turned on.

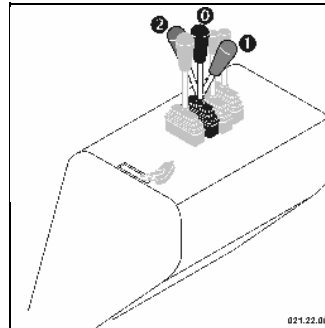

<b>2</b>	<b>UNSTABLE POSITION</b> The right track rotates forward
<b>0</b>	<b>STABLE POSITION</b> Resting position
<b>1</b>	<b>UNSTABLE POSITION</b> The right track rotates backwards
<p><i>fig. 18</i> <i>Command lever for the right track</i></p>	

### Command Lever for the Body

The command lever for the body activates the hydraulic jack that provokes the overturning of the body.

This position ② can only be used with the motor turned on, while this position ① can also be used when the motor is turned off.

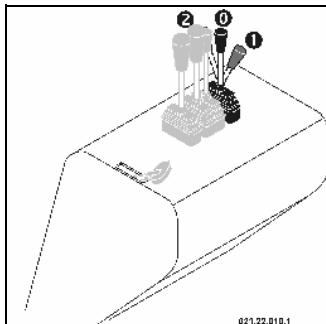



②	<b>UNSTABLE POSITION</b> The body overturns
①	<b>STABLE POSITION</b> Resting position
①	<b>UNSTABLE POSITION</b> The body lowers
<p><i>fig. 19</i> <i>Command lever for the body</i></p>	

### Command Lever for the Speed

The speed command lever takes effect on the traction hydraulic circuit, obtaining an increase of traslation of the machine.

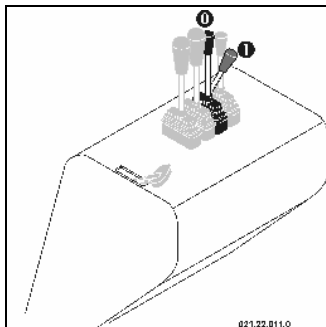
The position ① must be utilized only for travelling gear.



①	<b>STABLE POSITION</b> Slow Speed	
①	<b>STABLE POSITION</b> Fast Speed	
<p><i>fig. 20</i> <i>Command lever for the speed</i></p>		



**Accelerator Command**

Allows variations in the rotation regimen of the motor to obtain the required power.

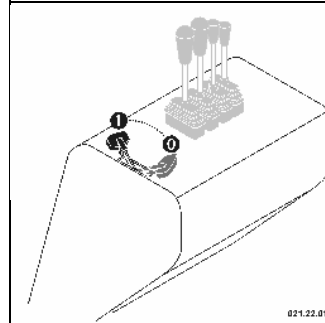

0	<b>STABLE POSITION</b> Minimum regimen
...	<b>STABLE POSITION</b> Intermediate regimens
1	<b>STABLE POSITION</b> Maximum regimen

*fig. 21*  
*Command for the accelerator*

**2.3. "HI-TIP" VERSION**

**Drive Levers**

**Left Drive Lever**

The left drive lever control the rotation of the left track through a hydraulic feed to the hydraulic motor.  
The lever is active only when the motor is turned on.

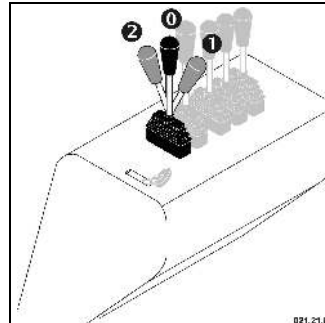

2	<b>UNSTABLE POSITION</b> The left track rotates forward
0	<b>STABLE POSITION</b> Resting position
1	<b>UNSTABLE POSITION</b> The left track rotates backward

*fig. 22*  
*Left track command lever*

### Right Drive Lever

The right drive lever control the rotation of the right track through a hydraulic feed to the hydraulic motor.  
The lever is active only when the motor is turned on.

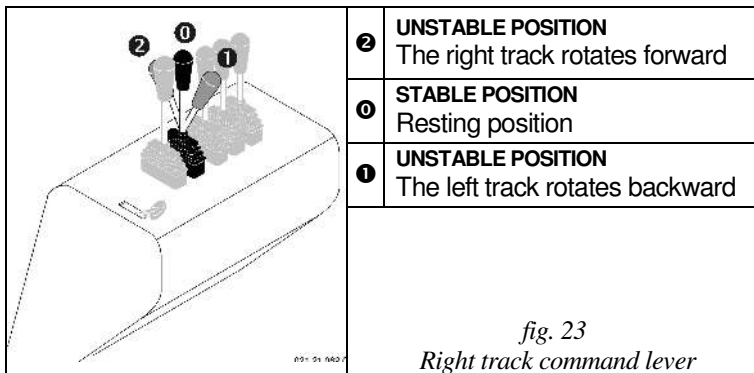

### Command Lever for the Body

The command lever for the body activates the hydraulic jack that activates the tipping of the body.

This position **2** can only be used with the motor turned on, while this position **1** can also be used when the motor is turned off.

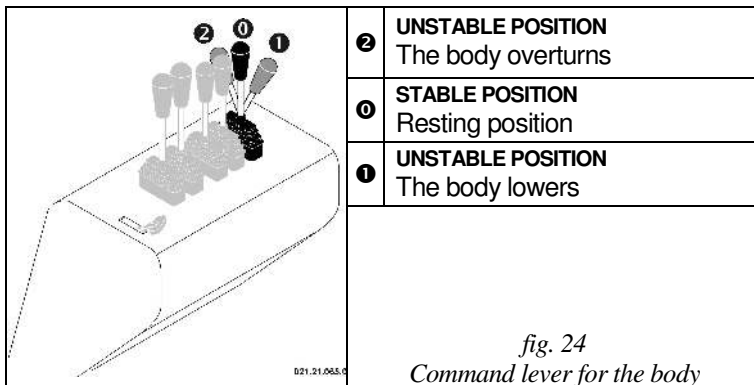

### “Hi-Tip” (High Unloading) Command Lever

The command lever the “Hi-Tip” works the hydraulic jack that provokes the raising of the anchoring structure of the body to consent the unloading in containers or tubs with a high border.

The command may be used only when the motor is on.

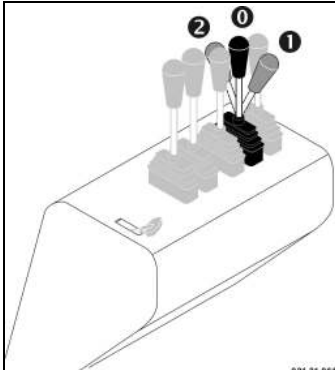



2	<b>UNSTABLE POSITION</b> Allows the body to be raised
0	<b>STABLE POSITION</b> Resting position
1	<b>UNSTABLE POSITION</b> Provokes the lowering of the body
<p>fig. 25 “Hi-Tip” Command Lever</p>	

### Command Lever for the Speed

The speed command lever takes effect on the traction hydraulic circuit, obtaining an increase of traslation of the machine.

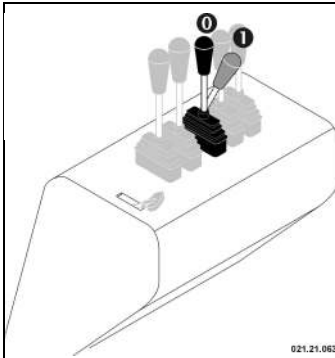
The position 1 must be utilized only for travelling gear.



0	<b>STABLE POSITION</b> Slow Speed	
1	<b>STABLE POSITION</b> Fast Speed	
<p>fig. 26 Command lever for the speed</p>		

### **Accelerator Command**

The command lever of the accelerator acts upon the motor and allows one to vary the rotation regimen in order to obtain the required power.

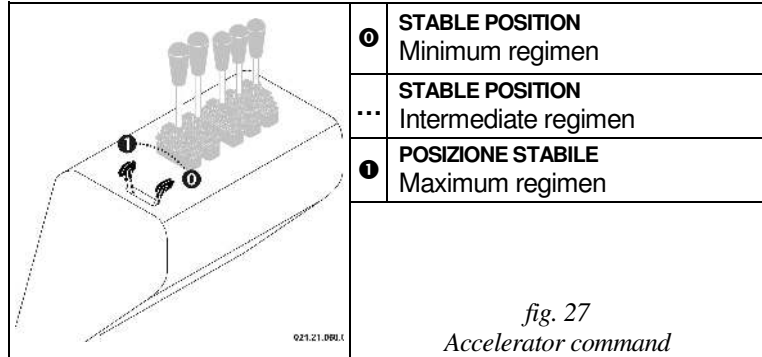

### 3. INSTRUCTIONS FOR USE

---

#### 3.1. FIRST USE

---



**READ CAREFULLY:** before using the machine you must read all of the instructions in this manual and the user's and maintenance manual of the motor installed on your machine scrupulously. Furthermore, always keep it attached to the machine..

The machine is normally delivered completely assembled and ready for use with an empty fuel tank.

Fill the fuel tank, open the fuel tap and follow the start-up procedure described in the appropriate paragraph.

#### 3.2. BREAKING-IN PERIOD

---

The technology used during the construction of your machine does not require a break in period. However, during the first period of use, it is necessary to use these precautions:

☞ During the first 50 hours, avoid using the motor at over 70 % of the total power.



**READ CAREFULLY** Read the user's manual and the maintenance manual for the motor installed in your machine carefully and follow the instructions prescribed for its own break in period.

- ☞ After the first 20 hours of operation, check the level of the hydraulic oil in the tanks.
- ☞ During the first period of use, the tracks undergo an adjustment, for which it is necessary, after the first 50 hours of operation, to carry out the regulation of the tension of the tracks.

#### 3.3. MOTOR START-UP

---

Every time you wish to start up the motor, always verify and adhere to the following indications scrupulously:

- Always start up the motor outside and be certain that there are no other persons in the vicinity of the machine and/or other impediments.
- Check that there is fuel in the tank and, if necessary, add some.



**WARNING:** Before turning on the motor, always insert the parking brake to avoid eventual movement of the machine that could present safety issues for the operator.

- Follow the specific procedure prescribed by the constructor of the motor shown in the attached instructions.

When the motor is hot, in petrol operated motors, avoid inserting the starter.

#### 3.4. REFUELING

---



**DANGER:** Refuelling must always be done with the motor turned off! Do not smoke while refuelling or while handling fuel to avoid the risk of fire!

Refuelling and /or movement of the fuel from one container to another must always be done outside, always from fires or from other heat sources. Always check that the type of fuel is the correct one, specified for the motor of your machine.

- Position the machine on a clean surface.
- Unscrew the plug slowly.
- Pour the fuel into the tank slowly.
- Screw the plug on again tightly.



- Immediately dry any fuel spills.
- WARNING:** Start up the motor only after having made certain that there are no traces of fuel that have accidentally spilled out!



**WARNING:** The conservation of the fuel must always be done with respect for the specific laws, in suitable places, away from sources of heat, and with clean, well closed suitable containers!



**REQUIRED:** Avoid the dispersion of fuel and/or fuel containers in the environment. Carry out the disposal according to the current laws and with respect for the environment.

#### 3.5. DRIVING THE MACHINE

---



**WARNING:** Where possible, try to avoid travelling on rocky or icy terrain, on rails and railway sections because they may damage the tracks and reduce their longevity. Also avoid passing over material that could ruin the tracks, such as sharp objects, pieces of metal, etc. that could get caught up in the tracks and provoke a break.



**DANGER:** Always avoid overloading the machine above the prescribed limits: during movement, an overload could create structural variations that were not foreseen and could provoke the overturning of the machine with serious safety consequences.

At the start-up, regulate the number of rotations of the motor to the desired level by activating the accelerator lever, according to the required power (when the machine is loaded, you must bring the lever above the halfway mark between the minimum and maximum).

Under certain conditions, especially when the machine is loaded or going uphill, a loss of engine power may occur because of a motor overload; this may also cause it to shut down. In this case, slowly release the drive command lever, regulating the speed to a level that does not provoke an overload of the propeller.

Being a machine equipped with a hydrostatic transmission, **it is not necessary that the rotations of the motor are at their maximum** for the transfer. Leaving the motor operating at its maximum number of rotations does not improve the functioning of the machine, rather **it certainly (an uselessly) increases its fuel consumption**: it is advisable, therefore, to increase the rotations of the motor only where it is absolutely

necessary (to proceed at maximum speed, to address steep slopes with a full load, etc.).

### 3.5.1. DRIVING POSITION

Your machine is driven manually and its speed and stability are operated with the feet.

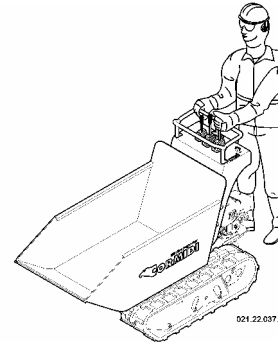

fig. 28 – Driving position

When the machine is in gear, always grasp the stronghold handle firmly with one hand and use the other hand simultaneously to activate both drive levers.

**Never release the handle to operate the command levers with**

**both hands.**



**DANGER:** When the machine is in gear, the operator must always maintain the prescribed driving position and must avoid letting the machine advance without a driver.

Never speed when working, rather proceed at a speed adjusted to your walking speed, in this way you will maintain a safe control over the commands.

### 3.5.2. FORWARD GEAR

To allow the machine to advance one must activate both drive levers simultaneously by pushing them forward.

Avoid addressing downhill slopes in forward gear, refer to the paragraph “*Travelling on Slopes*”.

### 3.5.3. REVERSE GEAR

To allow the machine to back up you must activate both drive levers, pulling them back simultaneously.

Avoid addressing uphill slopes in reverse gear, especially with a loaded machine, rather follow the procedure described in the paragraph “*Travelling on Slopes*”.



**DANGER:** While in reverse gear, always check to see that there are no obstacles and/or persons in the vicinity.

### 3.5.4. TRAVELLING ON SLOPES

When addressing sloped segments, especially when the machine is loaded, one must use this particular technique:

- ☞ Always address uphill slopes in forward gear;
- ☞ Always address the downhill slopes in reverse gear.

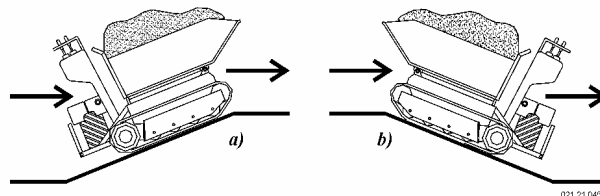

fig. 29 – a) going uphill; b) going downhill



**DANGER:** Completely avoid working on terrains that have lateral slopes of more than 10° and longitudinal slopes of more than 20° to avoid the possibility of overturning with serious consequences for the safety of the operator.

On high slope ground is necessary to work with high regimen of motor (as the slope) minimizing the opening of drive levers (see fig. 30); otherwise could be verify cavitation problems and missing the “engine-brake” effect (the hydraulic motors are forced by the slope and they function like a pump): if the machine increase the speed “alone”, release the drive levers.



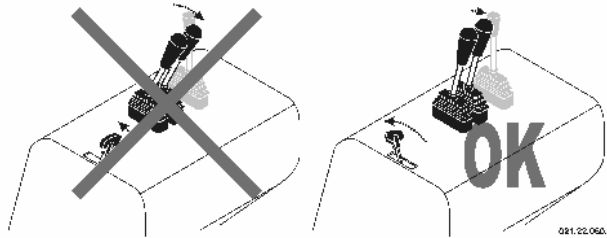

fig. 30 - Motor regimen going downhill



**DANGER:** if the machine travelling on high slope with minimum motor regimen and maximum opening of drive levers, “engine brake” effect is missing and the machine could increase the speed out of control with the possibility of serious consequences for the safety of operator and the proximity persons.

### 3.5.5. FAST GEAR

Using the fast gear allow to increase the transportation speed of the machine, to the detriment of torque and of starting power or to address slopes and maneuvers, especially when the machine is loaded.

It's necessary to restrict the use of fast gear only for travelling on plain and not uneven ground, without

obstacles.

### 3.5.6. STOPPING MOVEMENT

To stop movement one must release the drive levers for the track simultaneously.

### 3.5.7. MOVEMENT IN CURVES

To allow the machine to turn one must release the lever on the side to which one intends to turn:

- ☞ To turn to the right, release the right-hand drive lever;
- ☞ To turn to the left, release the left-hand drive lever.

The steering is determined by the slowing of the speed of one track with respect to the other. Consequently the speed and the degree of steering are proportional to the intensity of the release and to the pressure with which you apply to each lever.

### 3.5.8. COUNTER-ROTATION

It is also possible to make the machine spin round, carrying out a complete “counter-rotation” around its axis, in order to carry out manoeuvres in small spaces.

Using the counter-rotation manoeuvre often reduces the duration of the rubber tracks, especially if you do it upon rough surfaces.

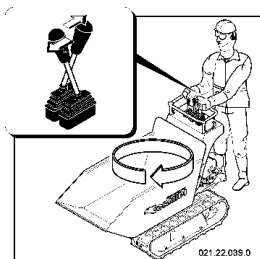

☞ To make a clockwise counter-rotation (towards the direction of the clock hands) you must push the left-hand lever forward and pull the right-hand lever back.

fig. 31 – Clockwise counter-rotation

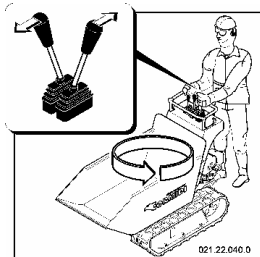

☞ To make a counter-clockwise counter-rotation (towards the opposite direction of clock hands) you must push the right-hand lever forward and pull the left-hand lever back.

fig. 32 – Counter-clockwise counter-rotation

### 3.6. SHUT DOWN AND PARKING



**WARNING:** If you move away from and leave the machine unattended, be certain that no unauthorized person may turn it on or move it. Always turn the start up switch to the position “0”.

Before shutting down the machine, position yourself

preferably on a paved and level surface, or a level terrain that is stable and compact.

- Using the accelerator lever, bring the motor down to a minimum number of rotations;
- Always turn the start-up switch to the position: “0”;
- Close the fuel tap (on motors that are equipped).

### 3.7. TRANSPORTING LOADS



**PROHIBITED:** It is strictly prohibited to surpass the carrying limits indicated in the table on page 9.

#### 3.7.1. CONSTRUCTION BODY (DUMPER)

The machine is equipped with a “dumper” type body to transport inert and solid materials, suitable mainly to be used for construction work.

#### 3.7.2. “FARMING” TYPE BODY

Upon request, your machine may be fitted, in place of the “dumper” type body, with a body that has sides that can be opened, and is suitable to transport farming materials. The opening of the sides allows one to enlarge the loading surface to be able to transport cumbersome objects.

To obtain a larger loading surface, work with one side

at a time as follows (see fig. 33):

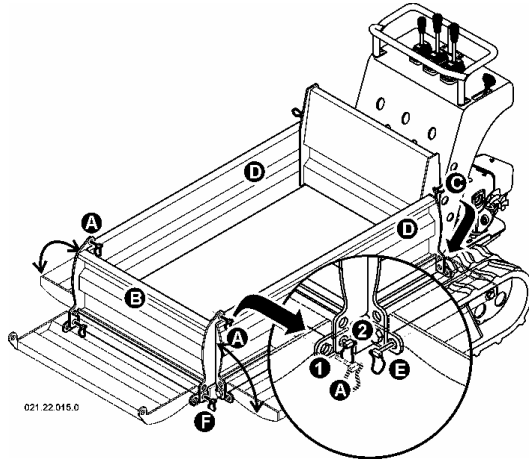

fig. 33 - Farming body

- Take out the two pins “A” beforehand;
- Free the anterior side “B” and open it;
- Block the side in the lowered position using the two pins “A” and inserting them in the openings “1”;
- Take out pin “C” and lower the lateral side “D”;
- Block the “D” side using pin “C” and pin “E” present at the base of the side, in the anterior part;
- Repeat the operation on the other side;
- Be sure that the pins are blocked and position the

load so that it will not fall.

### 3.8. UNLOADING MATERIAL

Your machine is equipped with a hydraulic dumping device for the body which allows the unloading of the material.

#### 3.8.1. UNLOADING THE BODY



**WARNING - Before unloading, be certain that the terrain is flat, solid and compact. Carry out the dumping manoeuvre slowly and uniformly. Do not move forward with the machine during the dumping phase.**

To carry out the dumping manoeuvre:

- Position yourself on a level, solid, and compact surface or terrain;
- If the machine is equipped with a farming body, unblock the anterior side “B” (see fig. 33) by taking out the two pins “F”;
- Push the lever forward to provoke the overturning of the body and the unloading of the material;
- Pull the lever back until the body has returned to travelling position, and then release the lever;
- • In the case of the **farming body**, reposition the pins “F” to avoid the accidental opening of a side.



**CAUTION:** During the unloading, if the body hits up against an obstacle, avoid moving the machine forward: this could damage the connecting points of the body!



**PROHIBITED:** It is strictly prohibited to travel if the body is not in its resting position.

### 3.8.2. RAISING THE BODY (“HI-TIP”)

On request the machine may be equipped with a hydraulic device to raise the body during the unloading to allow for unloading in containers or tubs with high walls, named “Hi-Tip”.

To unload material normally, use the lever for the overturning of the body (as indicated in the preceding paragraph).

To carry out a high unloading, proceed as follows:

- Position yourself on a level surface or on a level, solid, and compact terrain;
- Use the lever of the auto-loading device pushing it forward to place the shovel on the ground in order to stabilize the machine;
- Raise the body to the desired height by pushing forward the lever for raising;

- Push the overturning lever for the body forward to allow for the unloading of the material.

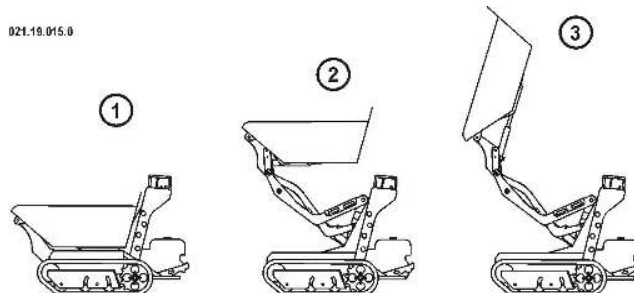

*fig. 34 - Position for high unloading*

To bring the body back to a driving position, proceed as follows:

- Pull back the overturning lever and bring the body back to a horizontal position;
- Release the command lever for the body
- Pull the lever for raising the body backward until it has reached the driving position;
- Release the raising lever.



**DANGER:** Never carry out the raising of the body without first stabilizing the machine with the auto-loading shovel.



**DANGER:** Never, for any reason, activate the raising lever while driving. You could provoke the overturning of the machine

### 3.9. TRANSPORT

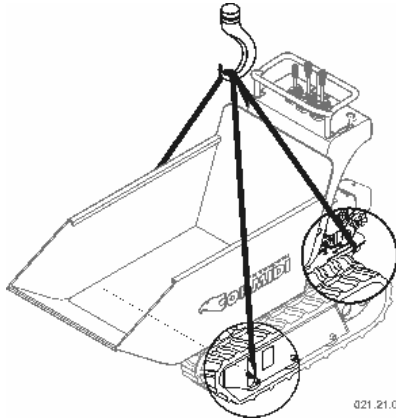

021.21.048.0

*fig. 35 – Anchoring points to lift machine*

If the machine needs to be transported, one must proceed correctly to avoid dangers to persons and/or to the machine. Given the weight of the machine, it is not possible to move it manually. Thus, it is necessary to use suitable means of lifting to load it onto a means of transport.

To carry out this operation under the safest conditions possible, proceed as follows:

- Empty the fuel tank and close the plug;
- Fix the lifting hooks exclusively to the anchoring points that were prescribed by the manufacturer;
- Fix it firmly to the surface of the means of transport pulling down firmly, and always connecting the points indicated in the figure.

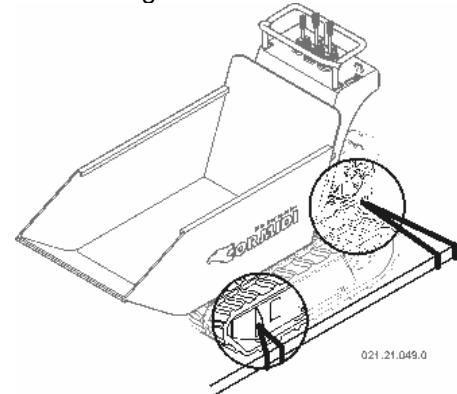

021.21.049.0

*fig. 36 – Anchoring points for transportation*



**WARNING:** During transport, always position the machine levelly to avoid the spilling of oil or other liquids.



**WARNING: Raise the machine by hooking it exclusively to the hooks predisposed for this: the anchoring of the machine in other points can cause breakage with the consequent fall of the machine and can cause serious harm to persons.**

- Always turn the motor's ignition switch to the "0" position.

When the machine is put back into service, you must once again carry out the greasing in all points specified by the relative chapter. Proceed with all operations regarding the motor that are described in its manual and check the oil level and, if necessary, add some.

### **3.10. STORAGE**

---

Whenever the machine must remain inactive for several months, it is necessary to provide a correct garaging so that the machine is in perfect working order when it is used again.

Carry out the storage by following all of these instructions:

- Carry out all necessary repairs
- Empty the fuel tank completely
- Proceed with a careful cleaning and remove all cement, mud, and/or organic residues carefully;
- Proceed with all operations regarding the motor that are described in its own manual
- Carry out a greasing of all points listed in the specific chapter;
- Place the machine in such a way that it is sheltered from atmospheric agents under stable conditions and on a flat surface;

## 4. MAINTENANCE



**DANGER:** always carry out all maintenance operations with the motor off and with the ignition switch in the “0” position.

A good maintenance is necessary and is the secret to obtaining low running costs, to lengthening the life of your machine, and to always maintaining it at its highest efficiency.

Beyond the normal maintenance operations on the mechanic and hydraulic parts, it is a good rule to carry out a periodic washing of the machine and to proceed with a careful cleaning to take away all cement and/or mud residues that have been deposited. After every wash it is necessary to grease all of the parts that are subject to friction, as specified in the paragraph “Greasing”.

### 4.1. MAINTENANCE INTERVALS

To maintain the highest level of efficiency, it is necessary that the maintenance be carried out at regular programmed intervals.

In the following table a summary of the maintenance operations is listed that are to be carried out periodically.

### ( ) Maintenance and adjustment table

<i>Work Frequency</i>	<i>Description</i>	<i>Verify</i>	<i>Greasing</i>	<i>Cleaning</i>	<i>Adjustment</i>	<i>Substitution</i>
Every 8 hours	Machine			✓		
	Body		✓			
	Track rollers		✓			
	Motor oil <sup>(1)</sup>	✓				
Every 50 hours	Tracks				✓	
	Hydraulic oil	✓				
	Air filter <sup>(1)(2)</sup>			✓		
Every 200 hours	Motor wheel hubs		✓			
Every year or 300 hours	Hydraulic oil					✓
	Hydraulic Oil filters					✓
	Dry air filters <sup>(1)</sup> <sup>(2)</sup>					✓
	Motor oil <sup>(1)</sup>					✓
<sup>(1)</sup> Check with the attached manual for the motor						
<sup>(2)</sup> In dusty areas you must increase the frequency						

### 4.2. MOTOR



**READ CAREFULLY:** Read the instructions and the mode of use for the motor found in the attached specific manual carefully.

The machine that was delivered could be equipped at the origin with different engine types for specific needs and/or markets.

A correct maintenance is the best way to conserve the motor of your machine so that it is always at its fullest efficiency and this allows you to maintain low operation costs.

For the maintenance of the motor, pay scrupulous attention to the attached manual that was given to you.



**REQUIRED:** When changing the motor oil, always use a suitable aspirator to remove old oil. Avoid the dispersion of oil and filters in the environment and carry out their disposal with respect for the environment and the regulations in force.

### 4.3. HYDRAULIC SYSTEM

#### 4.3.1. HYDRAULIC OIL

##### Check level

<b>Every 8 hours</b>	Check the level of hydraulic oil in the tank.
----------------------	---

The correct level is when it is cool, the oil does not

surpass the line on the oil stick. (*see fig. 37*) (about  $\frac{3}{4}$  of the height of the tank) and does not reach more than 1 cm under the line.



**REQUIRED:** Avoid the dispersion of oil in the environment and carry out the disposal with respect for the environment and the regulations in force.

##### Restore Level

- Unscrew the top on the tank;
- Restore the level by adding the oil specified into the opening;
- Screw the top back on sealing appropriately, and turn on the motor by following the correct procedure;
- Briefly operate the drive levers and the command levers;
- Stop the motor and check. That the level reached by the oil on the stick is correct and, if necessary, repeat the operation.

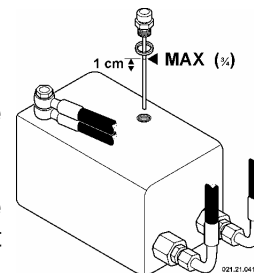

*fig. 37 – oil level*

##### Substitution

<b>Every 50 hrs</b>	<b>Substitute</b> the hydraulic oil in the tank
---------------------	---

To substitute the hydraulic oil, use a suitable aspirator.



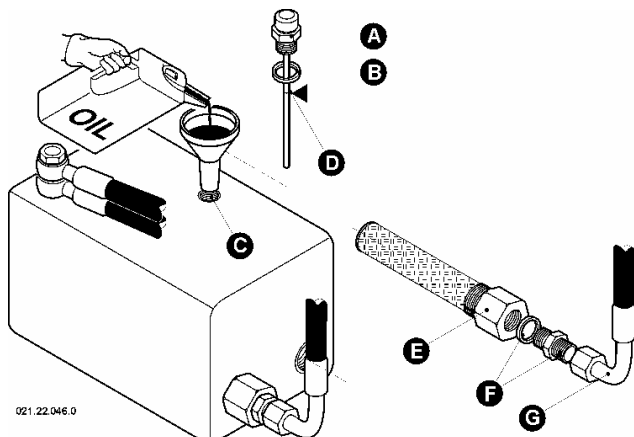

021.22.046.0

fig. 38 – Substitution of Oil and Filters



**DANGER:** The hydraulic oil can reach high temperatures: before emptying the tank, be sure that the oil is not hot to avoid risk of burning yourself.



**DANGER:** Always carry out the emptying operation when the motor is turned off, and with the body blocked by the appropriate bar.

Empty the tank beforehand;

- Unscrew the top “A” on the tank, taking away the washer “B”
- Vacuum the oil completely using the suitable aspirator;
- Fill the tank from the opening “C” until the red line is reached;
- Screw the top “A” back on with its washer “B” and turn on the motor;
- Briefly operate the drive and command levers;
- Turn off the motor and check that the level has reached the line “D”, and if necessary, add more;
- After 8 hours of working, check the level again.

#### 4.3.2. HYDRAULIC OIL FILTER

Your machine is equipped with two filters on the hydraulic oil circuit, positioned in the lower part of the frame, under the body. The filters, which are immersion type, are screwed directly into the tank (v. fig.38).



**DANGER:** Always substitute the filters when the motor is shut off and the body is blocked by the appropriate bar.



**REQUIRED:** Carry out the disposal of the oil and filters with respect for the environment and for the regulations in force.

<b>Every 50 hrs</b>	<b>Replace</b> the hydraulic oil filters.
---------------------	---

The filter in the circuit which feeds from the auxiliary service pump is an immersion type and is screwed directly in the lower tank.

**Replacement** : to replace the filter use the following instructions (*v. fig. 38*):

- Empty the oil tank, following the correct procedure;
- Unscrew the oil tube “G” by working on the junction;
- Unscrew the filter “E” and take it out of the tank;
- Put the nipples “F” on the new filter always checking the lining;
- Screw the filter back into the tank;
- Screw the oil tube “G” back to the nipples “F”;
- Fill the tank and check the level.

#### 4.4. TRACKS

##### Registration

<b>Every 50 hrs</b>	<b>Register</b> the tension of the tracks.
---------------------	--

The correct tension of the tracks is important in order to guarantee their longevity and for your own safety: to check it, apply a pressure of 5 kg on the track and check that the arrow is at about 30mm.

To carry out the regulation of the tension of the tracks correctly:

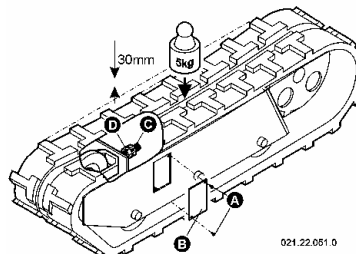

*fig. 39 - Regulation track tension*

- Take of the cover “B” by unscrewing the two screws “A”;
- Using two wrenches, loosen the counter-nut “C”;
- Regulate the tension by working on nut “D”;

- Check that the arrow is at 30 mm;
- When you have finished regulating, block the counter-nut;
- Put the cover back on;
- Repeat the same procedure on the other track.

##### Substitution



**DANGER:** Never work with the machine raised on a jack or suspended, rather always place it upon suitable trestles that can maintain the weight of the machine before starting work.

For the substitution of the tracks, proceed as follows:

- Raise the side of the machine on which you wish to work using hydraulic jacks or a crane;
- Position the machine on suitable trestles, and check to see that it is stable;
- Take off the cover "B" by unscrewing the screws "A";
- Using two wrenches, loosen the counter-nut "C" and completely unscrew both the counter-nut and nut "D";
- Take off the track "E" starting from the anterior part;
- Mount the new track lining it up with the teeth in the drive wheel "F";
- Fit in the anterior part of the track onto the neutral wheel "G";
- Register the tension by working on nut "D";
- Check that the arrow is at 30mm;
- When the registering is done, block the counter-nut "C";
- Put the cover back on.

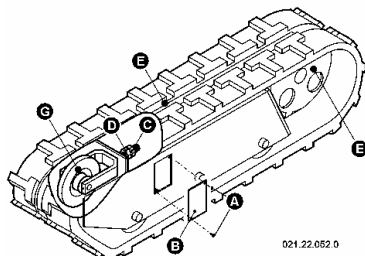

fig. 40 - Sostituzione cingoli

#### 4.5. GREASING

**Every 8 hrs**

**Refurnish the grease** in all prescribed points.

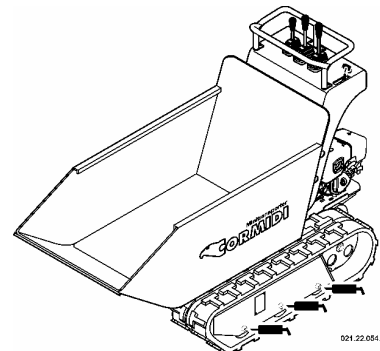

fig. 41 - Greasing Points

Refurnish the grease in all prescribed greasing points, using a suitable grease.

#### Hub Wheel

**Every 200 hrs**

**Grease** the hubs of the wheels.

Periodically it is also necessary to refurnish the grease on the hubs of the drive wheels, a procedure that is done as follows, **always working on one side at a time**:

- Completely unscrew and take out screw “A” and the washer “B” that block the drive wheel “C”;
- Completely fill the cavity with grease;
- Screw back screw “A” always checking the washer;
- Repeat the procedure on the wheel on the other side.

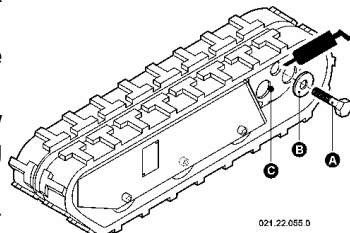

fig. 42 –Greasing hub wheel

#### 4.6. RECOMMENDED LUBRICANTS

---

	<i>Type</i>	<i>Quantity</i>
Motor Oil	<b>15W40</b>	
Hydraulic Oil	<b>ATFII</b>	<b>16 l</b>
Grease	<b>MR Filante</b>	

## 5. TROUBLESHOOTING

Fault	Possible Causes	Solution
Hydraulic oil is leaking.	Excessive oil level	Correct the oil level.
	Overheated oil	Turn off the machine and let it cool down.
	Breakdown in the hydraulic circuits	Have the machine looked at by a mechanic with this specific competence
Oil leak	Excessive oil level	Correct the oil level
	Breakdown in hydraulic circuits or in lining	Have the machine looked at by a mechanic with this specific competence
The hydraulic commands do not respond correctly.	Insufficient oil level.	Refill to the correct level
	Breakdown in the hydraulic circuits.	Have the machine looked at by a mechanic with this specific competence
The body moves slowly.	Overheating of the oil.	Interrupt work and let it cool down
	The motor does not have power	Have the motor looked at by a mechanic with this specific competence
Excessive oil temperature.	Insufficient oil level.	Refill to the correct level
	Overheating.	Interrupt work and let cool down.
The machine does not move.	Not enough oil in the hydraulic circuit.	Restore oil to the correct level.
	The tracks are broken.	Replace the tracks.
	Breakdown in the hydraulic components	Have the motor looked at by a mechanic with this specific competence
Excessive noise from the tracks during movement	Incorrect track tension.	Register the tension
	Broken or worn tracks	Replace the tracks
	Broken rollers or ball bearings	Have the machine repaired by a mechanic

---

---

<b>Fault</b>	<b>Possible Causes</b>	<b>Solution</b>
Excessive noise during the rotation of the barrel.	Not enough grease.	Grease
	Breakdown in the bearings	Have the machine repaired by a mechanic
The accelerator does not respond.	The accelerator cable is broken.	Replace the cable at a mechanic's.
The motor does not work correctly or makes an excessive amount of noise.	Various causes.	Have the motor looked at by a mechanic who has expertise in this area.
	The air filter is blocked	Replace the air filter
The motor does not develop power.	Various causes	Have the motor looked at by a mechanic who has expertise in this area
The motor will not start.	Not enough fuel	Refuel the machine
	The start-up procedure was not carried out correctly	Follow the correct start-up procedure
	The battery is dead	Have the battery recharged or replace it

---

**6. INDEX**

---

Accelerator		Leva dell'Hi-Tip	17	GENERAL Information	1
Lever	12; 15	Leva dello Scarico alto	17	Goal of the Manual	1
Registering	<i>See Attachment</i>	Leva di Guida	15	Greasing	
Acceleratore		Command	11	Hub Wheel	33
Leva di Comando-	18	Accelerator Lever	12; 15	Points of -	33
Accessories	6	Double Speed Version	13	Guida	
Admissible Slopes	9	Drive Lever	11; 13	Leve di -	15
Air Filter		Hydraulic Tipping Version	11	Hi-Tip	
Cleaning	<i>See Attachment</i>	Lever for the Body	12; 14	Leva di Comando-	17
Substitution	<i>See Attachment</i>	Lever for the Speed	14; 17	Raising the Body	26
Blocking the Body	5	Twin Version	13	Hub Wheel, Greasing	33
Body		Construction Body (Dumper)	24	Hydraulic Oil	30
Blocking the-	5	Counter-Rotation	23	Restore Level	30
Command Lever	12; 14	Devices		Substitution	30
Construction - (Dumper)	24	Safety	5	Hydraulic System	
Farming Type	24	Dimensions	9	Maintenance	30
Raising (Hi-Tip)	26	Double Speed Command	13	Identification Manufacturer and Machine	4
Unloading the -	25	Drive		Identification Tag	4
Breaking-in Period	19	Levers	11; 13	Instruction for Use	19
Cassone		Driving		Introduction	II
Leva di Comando-	16	Position	21	Leva	
Ceaning Air Filter	<i>See Attachment</i>	the Machine	20	di Comando del Cassone	16
Check Level		Dumper, Construction Body	24	di Comando dell'Acceleratore	18
Hydraulic Oil	30	Farming Type Body	24	di Comando dell'Hi-tip	17
Motor Oil	<i>See Attachment</i>	Fast Gear	23	di Comando dello Scarico Alto	17
Comandi		First Use	19	di Guida	15
Versione Hi-Tip	15	Forward Gear	22	Level	
Comando		Gear		Hydraulic Oil	30
Leva del Cassone	16	Forward	22	Motor Oil	<i>See Attachment</i>
Leva dell'Acceleratore	18	Reverse	22	Lever	

---

Accelerator Command	12; 15	Minimum	<i>See Attachment</i>	Command Lever	14; 17
Command for the Body	12; 14	Registration		Stopping Movement	23
Command for the Speed	14; 17	Traks	32	Storage	28; 29
Drive	11; 13	Replacement		Substitution	
Machine		Hydraulic Oil Filter	32	Hydraulic Oil	30
Identification of -	4	Restore Level		Traks	32
Machine Description	2	Hydraulic Oil	30	Substitution	
Maintenance Intervals	29	Motor Oil	<i>See Attachment</i>	Air Filter	<i>See Attachment</i>
Manual, Goal of the -	1	Reverse Gear	22	Motor Oil	<i>See Attachment</i>
Manufacturer, Identification of -	4	Safety		Tag	
Minimum, Registering	<i>See Attachment</i>	Devices	5	Identification	4
Motor		Information	3	Safety	6
Maintenance	29; <i>See Attachment</i>	Tag Caution	8	Technical Data	10
Motor Oil		Tag Crushing	7	Traks	32
Check Level	<i>See Attachment</i>	Tag Cutting	7	Registration	32
Substitution	<i>See Attachment</i>	Tag Hot Surfaces	7	Substitution	32
Motor Start-up	19	Tag Maximum Slopes	8	Transport	27
Movement in Curves	23	Tag Procedure for Addressing Slopes	8	Transporting Loads	24
Oil Filter		Tag safety Distance	7	Travelling on Slopes	22
Hydraulic	31	Tags	6	Troubleshooting	35
Replacement -	32	Scarico Alto, Leva di Comando	17	Unloading Material	25
Parking and Shut Down	24	Shut Down and Parking	24	Unloading the Body	25
Raising the Body (Hi-Tip)	26	Slopes		Use	
Recommended Lubricants	34	Travelling on -	22	Instruction for -	19
Refueling	20	Speed		Warranty	1
Registering		Fast	23		
Accelerator	<i>See Attachment</i>	Speed			



**7. SUMMARY**

Introduction .....	II	3.1. First Use.....	19
1. General Information .....	1	3.2. Breaking-in Period.....	19
1.1. Warranty .....	1	3.3. Motor Start-up .....	19
1.2. Goal of the Manual .....	1	3.4. Refueling .....	20
1.3. Machine Description.....	2	3.5. driving the Machine.....	20
1.4. Safety Information .....	3	3.5.1. Driving Position.....	21
1.5. Machine and Manufacturer Identification.....	4	3.5.2. Forward Gear.....	22
1.6. Safety Devices .....	5	3.5.3. Reverse Gear .....	22
1.6.1. Blocking the Body .....	5	3.5.4. Travelling on Slopes.....	22
1.7. Accessories .....	6	3.5.5. Fast Gear.....	23
1.8. Safety Tags .....	6	3.5.6. Stopping Movement .....	23
1.8.1. Hot Surfaces.....	7	3.5.7. Movement In Curves .....	23
1.8.2. Crushing.....	7	3.5.8. Counter-Rotation .....	23
1.8.3. Cutting .....	7	3.6. Shut Down and Parking.....	24
1.8.4. Safety Distance .....	7	3.7. Transporting Loads.....	24
1.8.5. Procedure for Caution.....	8	3.7.1. Construction Body (Dumper) .....	24
1.8.6. Maximum Slopes .....	8	3.7.2. “Farming” Type Body .....	24
1.8.7. Procedure for Addressing Slopes.....	8	3.8. Unloading Material.....	25
1.9. Admissible Slopes.....	9	3.8.1. Unloading the Body.....	25
1.10. Dimensions .....	9	3.8.2. Raising the Body (“Hi-Tip”) .....	26
1.11. Technical Data .....	10	3.9. Transport.....	27
2. Commands .....	11	3.10. Storage.....	28
2.1. Hydraulic Tipping Version .....	11	4. Maintenance.....	29
2.2. Twin Version ( <i>Double Speed</i> ).....	13	4.1. Maintenance Intervals.....	29
2.3. “Hi-Tip” Version .....	15	4.2. Motor .....	29
3. Instructions for Use.....	19	4.3. Hydraulic System .....	30

4.3.1. Hydraulic Oil .....	30
4.3.2. Hydraulic Oil Filter .....	31
4.4. Tracks.....	32
4.5. Greasing .....	33
4.6. Recommended Lubricants.....	34
5. Troubleshooting .....	35
6. Index.....	37
7. Summary .....	39

---

---

## DICHIARAZIONE DI CONFORMITÀ

QUESTO DOCUMENTO CERTIFICA CHE LA MACCHINA SOTTO  
INDICATA È CONFORME IN TUTTE LE SUE PARTI  
ALLE SEGUENTI NORMATIVE:

Decreto di recepimento Italiano

- D.p.r 24/07/1996 n° 459

Direttive Europee

- 98/37/CE (Sicurezza del Macchinario)
- 2000/14/CE (Emissione acustica ambientale delle macchine ed attrezzature destinate a funzionare all'aperto)
- 89/336/CE (Compatibilità elettromagnetica)

Norme armonizzate (applicabili)

Prodotto: Dump per autotreno a trazione integrale compatto con cingoli in gomma per il trasporto di materiale pesante in cantiere.

Modello: \_\_\_\_\_

Numero di serie: \_\_\_/\_\_\_\_\_

Costruttore: CORMIDI srl- Via Seude snc 84050 Roccadaspide (SA)

Motore Tipo: Honda \_\_\_\_\_

Potenza Installata: kW \_\_\_\_\_

Certificato n° \_\_\_\_\_

Roccadaspide \_\_\_/\_\_\_/\_\_\_

**CORMIDI srl**  
*L'Amministratore*