

1 Tonne

Thwaites

Operator's Instruction Manual



Mach 202 – Powerswivel



Mach 201 – Hi-tip

January 2006: Issue 4
T0489



Thwaites Limited puts Safety First

It is the policy of Thwaites Limited to promote safety in the operation of its machines and to create a general awareness of site safety and safe working practices for the operators of its machines.

This Operator's Instruction Manual is intended for both new and experienced machine operators. It should remain with the machine at all times. All operators should be aware of its location and contents.

It is important that all operators are fully trained and familiar with the machine and that they have read and understood the information contained within this book before they attempt to operate in the site conditions for which the machine was designed.

This book details practices and operations which Thwaites Limited recommends. DO NOT operate this machine in ways other than those detailed within this book.

This machine is designed for customary construction site operations, and the transportation of bulk materials commonly carried on such sites; that is their 'intended use'. Under certain controlled conditions the dumper may be used for towing

wheeled loads.

Due to the varied nature of the operation of site dumpers and the absence of an agreed test standard, any figures quoted by Thwaites in relation to vibration values and exposure are for reference purposes only. It is the responsibility of the employer to assess vibration exposure based on the actual site conditions, and operating practices, at the point of use.

Hand Arm Vibration - The daily exposure Action/Limit Values of between 2.5 - 5.0m/s² (A8) are unlikely to be exceeded in an eight-hour reference period.

Whole Body Vibration - The daily exposure can only be accurately determined at the point of use. This exposure must be managed in respect of the Action/Limit Values of 0.5 and 1.15 m/s² (A8) respectively.

Employers should not rely solely on published vibration figures when undertaking risk assessments. Depending on the site conditions, cycle times may need to be adjusted in order to reduce operator exposure levels.

Vibration values based on typical duty cycles are available on request from Thwaites. These may be used for reference purposes only.

Safety Symbols



- Attention!
- Become alert!
- Your safety is involved!



- Correct action



- Incorrect action/procedure which should NOT be carried out

Signal words

Signal words are used on the machine and within this manual to identify levels of hazard seriousness:



DANGER



WARNING



CAUTION

1 Before operating this machine

Thwaites



Read operator's instruction manual



Thwaites
Distributor

1. Contact your Thwaites representative in case of further questions
2. Learn to operate this machine
3. Ensure you are fit to operate
4. Wear correct safety clothing and ensure that safety equipment is available

Complete Checks in Section



Before Starting The Engine

1 Before operating this machine

Thwaites

Walk around the machine

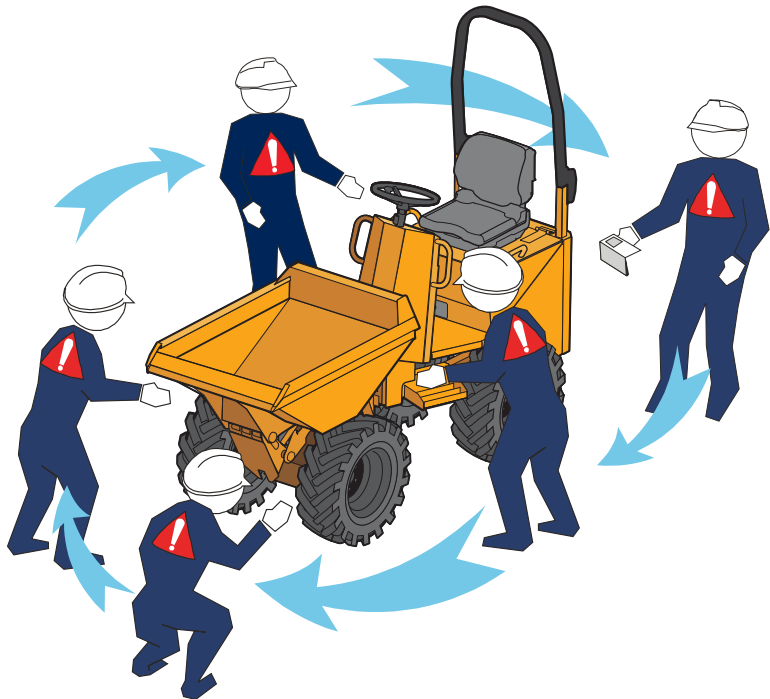

Visually check the machine

- 1 Are the chassis lock and the skip lock disengaged?
- 2 Are the controls, crush zone or hydraulic rams clean, and clear of any debris?
- 3 Is the Roll-Over Protective frame (ROPS frame) secure, fully upright and undamaged?
- 4 Is the seatbelt anchorage secure and serviceable?
- 5 Are the covers, mudguards and footplate secure?
- 6 Are the hoses free from fluid leaks?
- 7 Are all safety decals legible?
- 8 Are the tyres free of cuts or splits?
- 9 Are all bolts tight and in position?
- 10 **Have the daily maintenance tasks been performed? (See rear cover)**

Report all faults immediately.



DO NOT OPERATE THE MACHINE UNTIL ALL FAULTS HAVE BEEN RECTIFIED

Complete Checks in Section



Before Starting The Engine

1 Before operating this machine

Thwaites

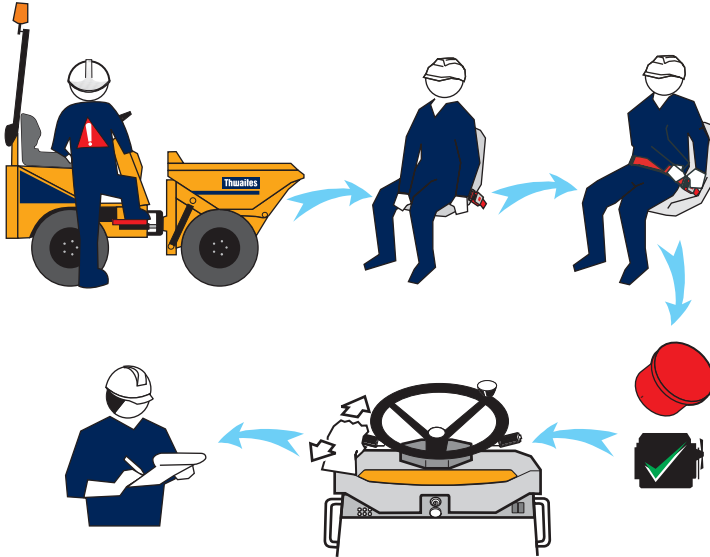

Mount the machine and check the controls

- 1 Use the grabrails and foot steps provided to manoeuvre into seating position. Face the machine at all times when mounting and dismounting
- 2 Is the engine cover secure and locked?
- 3 Adjust the seat position for comfort and easy access to controls
- 4 Fasten the seatbelt. Adjust accordingly for safety and comfort
- 5 Is the emergency stop button in a raised position?
- 6 Set the transmission to neutral
- 7 Do not operate the machine without understanding all its controls as described in the following pages



WARNING

Seatbelt **MUST BE WORN** when operating machines fitted with a ROPS frame.

Complete Checks in Section



Before Starting The Engine

1 Layout of controls

Thwaites

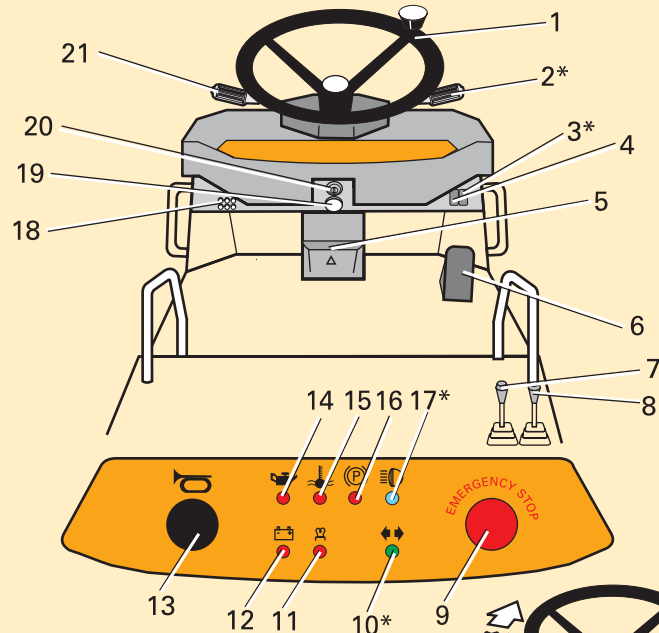

Control locations & functions

- 1 Steering wheel
 - 2 Lights switch*
 - 3 Hazard switch*
 - 4 Beacon switch
 - 5 Operator safety guide housing
 - 6 Throttle pedal
 - 7 Tip-skip lever (Hi-Tip model)
Tip-skip and rotate-skip lever (Powerswivel model)
 - 8 Raise-skip lever (Hi-Tip model only)
 - 9 Emergency stop button
 - 10 Direction lamp*
 - 11 Heat/start pilot light
 - 12 Battery charging warning light
 - 13 Horn push
 - 14 Engine oil pressure warning light
 - 15 Water temperature warning light
 - 16 Park brake applied light
 - 17 Full-beam lamp*
 - 18 Circuit breakers (push to reset)
 - 19 Warning buzzer
 - 20 Ignition switch
 - 21 Forward/neutral/reverse (FNR) lever
- *Optional features

- CB1 Fuel/Direction Solenoids.
- CB2 Instrumentation/Warning.
- CB3 L/H Sidelights.*
- CB4 R/H Sidelights.*
- CB5 Ignition Fed Lights.*
- CB6 Battery Fed Lights.*



Complete Checks in Section **1** Before Starting The Engine

1 Control functions – in depth

Thwaites

Seat adjustment

Type 1:

- A – Push down to set driver weight (seat empty)
Push fully down and release to reset (seat empty)
- B – Lift to slide seat assembly forwards/backwards
- C – Lift to slide cushion forward and set backrest

Type 2:

- E – Turn knob to set driver weight
- F – Lift to slide seat assembly forwards/backwards
- G – Lift handle to adjust backrest

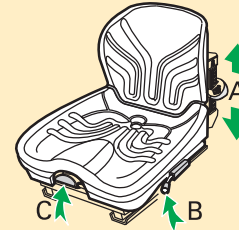

Type 1

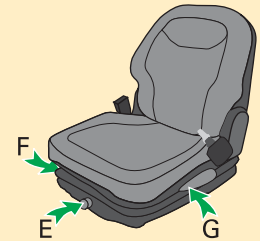

Type 2

Seatbelt

- Press grey seat belt button to release belt from housing
- Pull belt across body and press buckle blade into buckle lock
- Release belt by pressing red button on buckle lock
- Press grey button to retract belt into housing

 *Seat belt should not be worn loose, it should pass comfortably across hip bones and not the abdomen.*

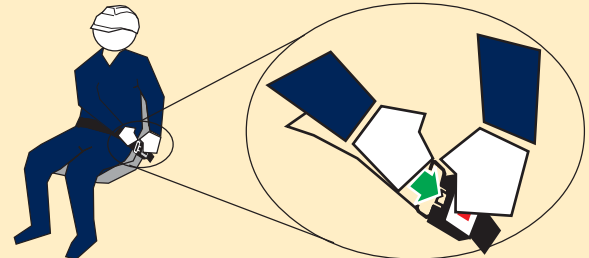

Complete Checks in Section



Before Starting The Engine

1 Control functions – in depth

Thwaites

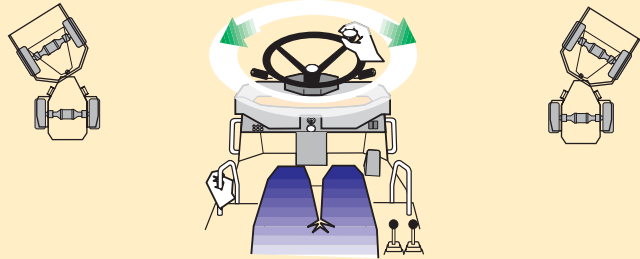

Steering wheel – both hands

- Turn the wheel clockwise to turn machine to the right
- Turn the wheel anti-clockwise to turn machine to the left



Ensure the non-steering hand is on the engine cover grabrail when using the spinner knob for low speed single-handed steering.

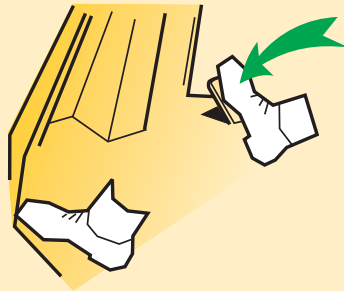

Throttle pedal – right foot

- Apply pressure to increase speed
- Release pressure from the pedal to reduce speed
- Fully release the pedal to stop



When throttle pedal is fully released, the transmission is set to neutral. After 2.5 seconds the park brake is applied.

Complete Checks in Section



Before Starting The Engine

1 Control functions – in depth

Thwaites

Tip-skip lever - Right Hand (Hi-tip & Powerswivel models)

- Push forward to discharge skip.
- Pull backwards to lower skip.

Raise-skip lever - Right Hand (Hi-tip model only)

- Push forward to raise skip.
- Pull backwards to lower skip.

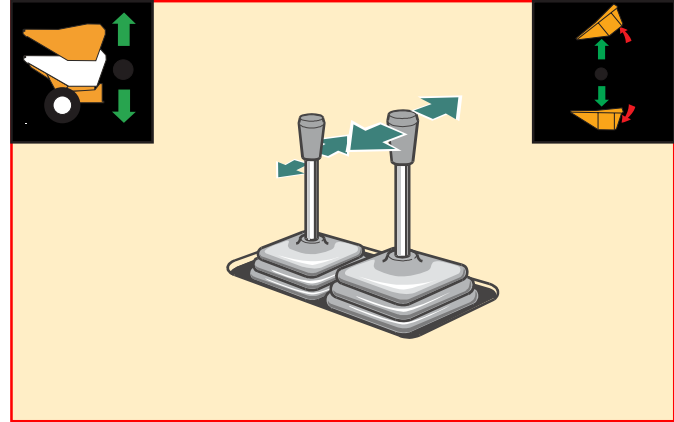

Skip-rotate lever - right hand (Powerswivel model only)

- Push lever to the right to rotate the skip clockwise
- Push lever to the left to rotate the skip anti-clockwise

 *Movement of the skip may slow if the steering wheel is moved (priority steering)*

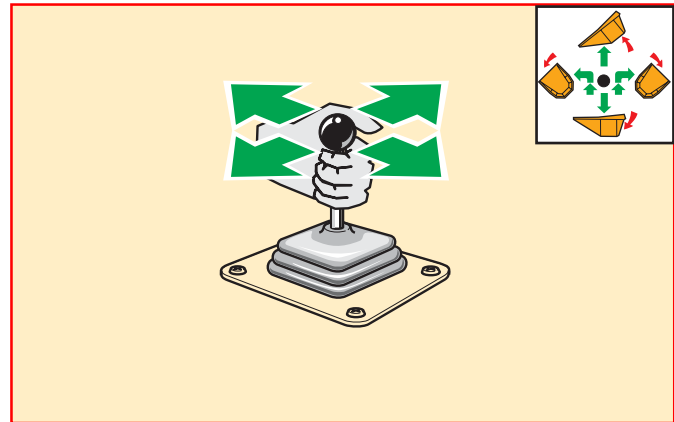

Complete Checks in Section

1

Before Starting The Engine

1 Control functions – in depth

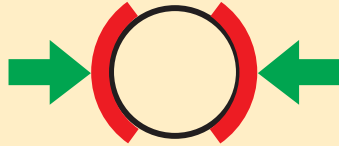

Automatic park brake (both rear wheels)

The park brake is applied in the following conditions:

- the FNR lever is in a neutral position
- the ignition switch is in an 'off' position
- the engine is stopped, with emergency stop button pressed
- the throttle pedal is fully released

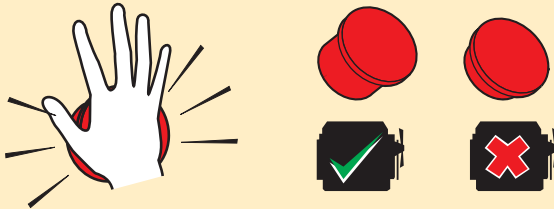

Emergency Stop Button - Right Hand

- Press to apply.
- Pull up to release.

If the emergency stop button is pressed, it will cause the engine to stop running. A warning buzzer and a warning light will be activated.

The automatic park brake is applied when the ignition is turned off, or if the emergency stop button is pressed.

1 Control functions – in depth

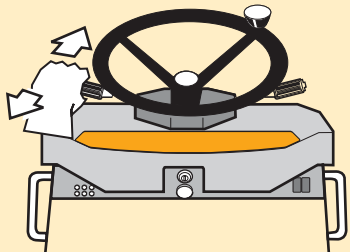
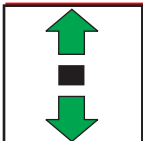

FNR lever - left hand

- Push forwards to travel forwards
- Lever centred = neutral
- Pull back to travel backwards

The automatic brake is applied when the FNR lever is in a centred (neutral) position for longer than 2.5 seconds.



WARNING

Stop machine before changing direction from reverse/forward and forward/reverse.

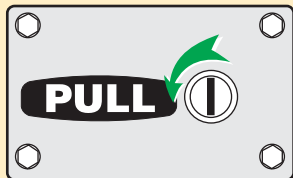

Engine Cover Open/Close

- Insert ignition key and turn anti-clockwise to unlock.
- Pull handle to release and raise cover.
- Lower cover, secure and turn key clockwise to lock.

1 Control functions – in depth

Lowering and raising the folding ROPS frame

- Remove beacon before lowering frame.
- Remove clips and withdraw frame lock pins.
- Lower frame and insert lock pins and clips in new position.
- Reverse the procedure to raise the frame.
- Ensure all pins are secure before driving.

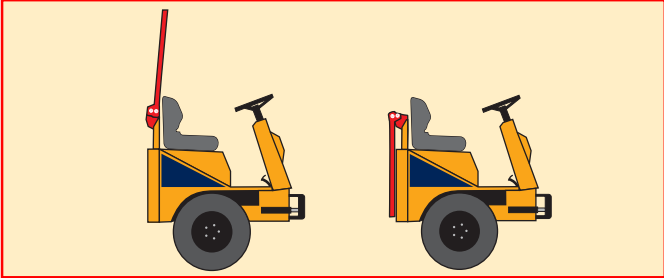

Beacon stowage

- Unplug and remove beacon.
- Secure beacon on bracket provided beneath bonnet.

Beacon switch/hazard switch*

- Push lower switch to activate beacon light.
- Push upper switch to deactivate beacon light.

*optional equipment

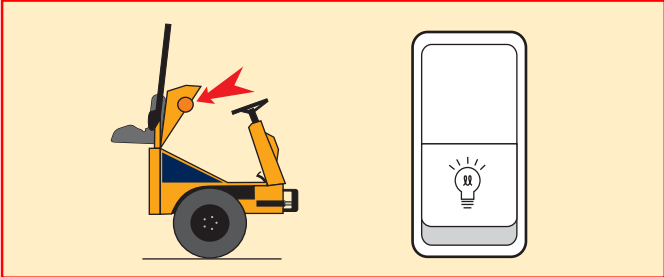

Battery isolator (*beneath engine cover*)

- Turn key anti-clockwise to isolate the battery power supply.
- Turn key clockwise to activate power supply.

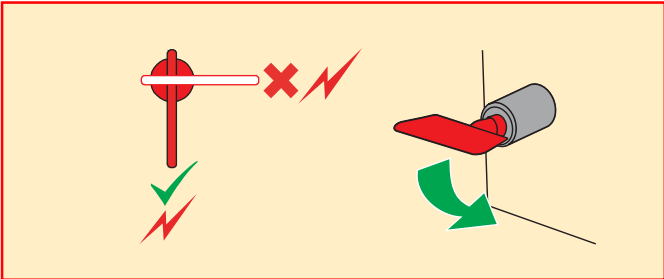

2 How to START and STOP the engine

Thwaites

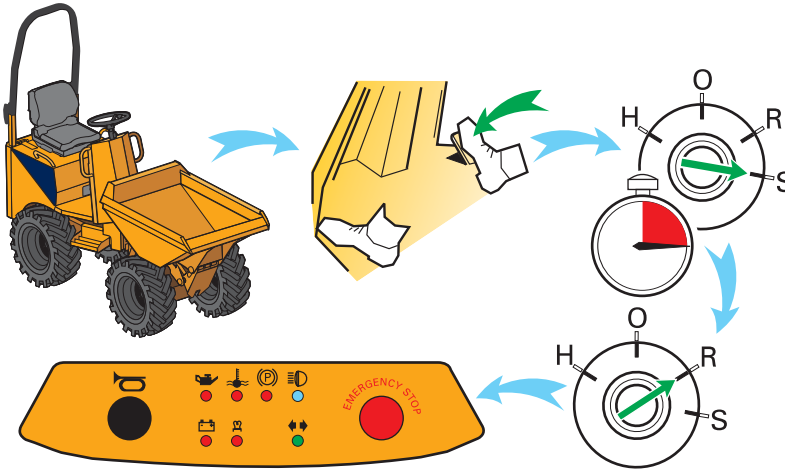

To start the engine:

- FNR lever to neutral.
- turn the key clockwise to the start position 'S'.

All panel lights self-test (illuminate) and should extinguish on start-up.

Cold Start Aid (below 0° C) -

Turn key to position 'H'. When panel light  extinguishes start engine (as above).

- Allow the engine to turn for 15 seconds max.
If the engine does not start within 15 seconds return key to position 'O' and wait 30 seconds before turning to 'S' again.
- When the engine fires, release key. (Springs back to 'Run' position 'R').

To stop the engine:

- Turn key to position 'O'.



CAUTION

- Do not use unauthorised starting aids.
- If a panel warning light remains on, switch off engine (key to 'O') and investigate the problem.
- This machine cannot be TOWED or BUMP started (see section 3 for recovery instructions).
- Do not engage the transmission until the self-test procedure is complete.

WARNING

DO NOT START THE ENGINE UNLESS SEATED IN THE DRIVING POSITION.

Complete Checks in Section  Before Starting The Engine

2 Preliminary Checks

Thwaites

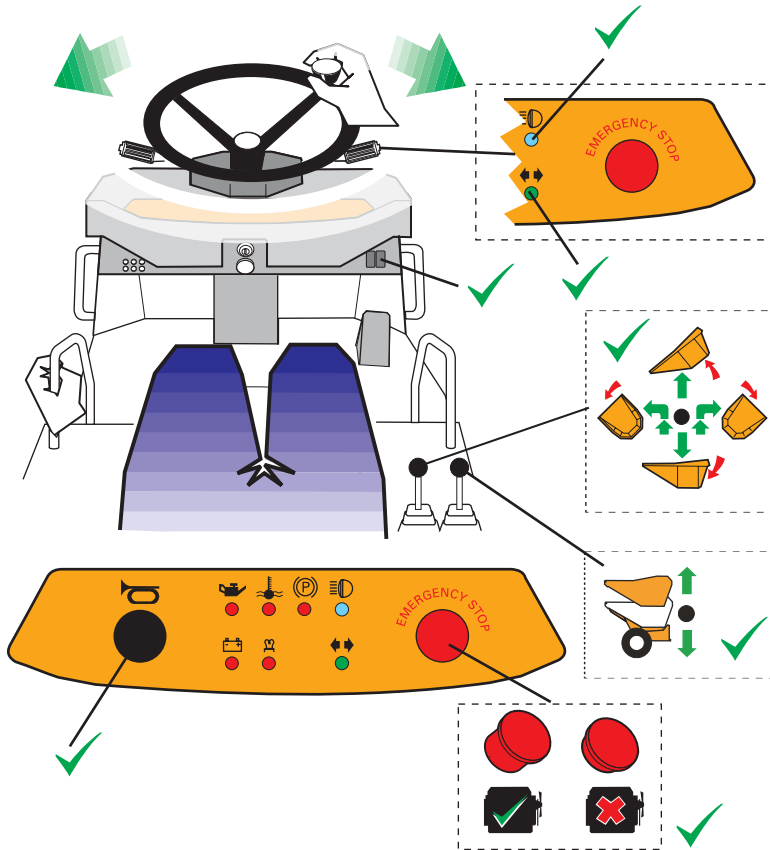

Function checks - engine ON

Steering:

- Rotate steering wheel clockwise and anti-clockwise.

Electrics:

- Does the horn sound correctly?
- Is the beacon flashing?
- Are the lights working correctly? (optional)
 - side
 - main
 - stop
 - indicators
 - hazards

Tip-skip lever:

- Tip and return the skip.
- Rotate the skip clockwise/anti-clockwise (powerswivel model only)

Raise-skip lever (Hi-tip model only):

- Raise and lower the skip.

Emergency stop button:

- Does the engine stop upon pressing?
- Does the warning buzzer sound upon pressing?

Reset the ignition switch after performing emergency stop checks.

CAUTION

Do not press throttle pedal during these checks.

Complete Checks in Section



Before Starting The Engine

2 Driving procedure and safe parking

Thwaites

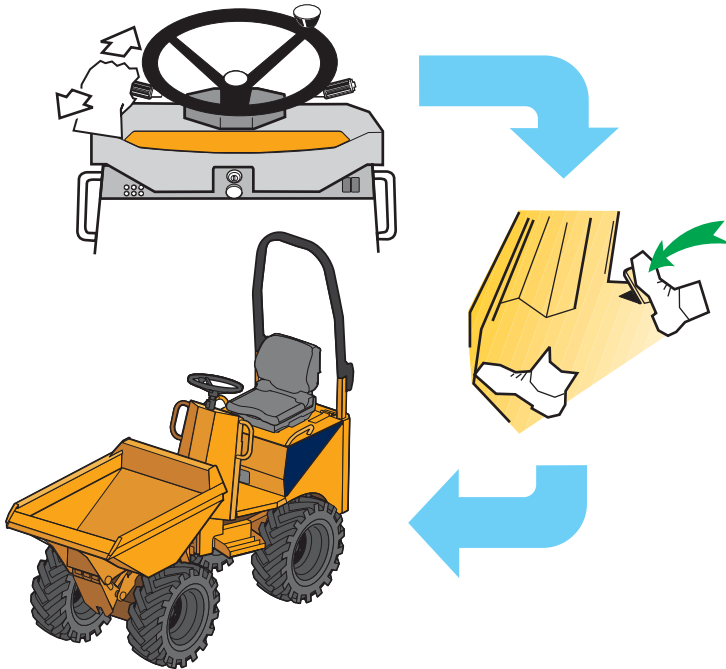

Moving from rest and stopping

- Select forward or reverse.
- Hold steering wheel with both hands.
- Slowly depress throttle pedal to move away.
- Remove foot from throttle pedal to slow and stop.
- Select neutral after stopping.

Park safely after operating:

- always leave skip empty in lowered position;
- ensure machine is on firm level ground;
- select neutral (FNR lever);
- stop engine and remove key;
- stow beacon for security (turn battery isolator off);
- lock engine cover.



WARNING - CHANGING DIRECTION

STOP machine before changing direction - forward/reverse or reverse/forward.



CAUTION

Novice operators should always begin with forward motion on clear, level ground.

Complete Checks in Section

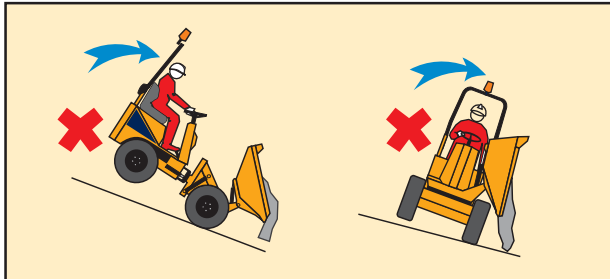
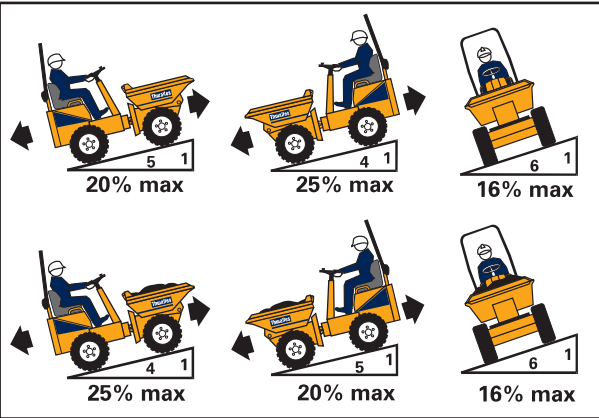

Before Starting The Engine

3**DANGER****IMMEDIATE HAZARDS WHICH WILL RESULT IN SEVERE PERSONAL INJURY OR DEATH****Thwaites****WORKING ON GRADIENTS**

DO NOT exceed maximum stated gradients



DO NOT turn across gradients



DO NOT run down hill with controls in neutral



DO NOT work on rough or rutted ground, or drive across kerbs etc.



DO NOT operate raise, or tip the skip on sloping ground



DO NOT discharge load when working on sloping ground.



Travel straight up, down or along a gradient, keeping speed to a minimum.



To prevent movement when leaving the machine unattended on sloping ground, always turn off the ignition (this will engage the automatic brakes). Chock wheels securely .



Always position the skip in a forward-facing position. (Powerswivel model only)

Attention! Section*Correct and Incorrect Working Practices*

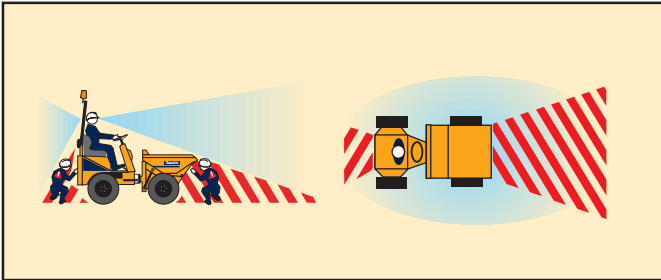
3**DANGER****IMMEDIATE HAZARDS WHICH WILL RESULT IN SEVERE PERSONAL INJURY OR DEATH****Thwaites****VISIBILITY**

Check ahead and behind machine before operation.



Be aware of low-visibility areas when operating.

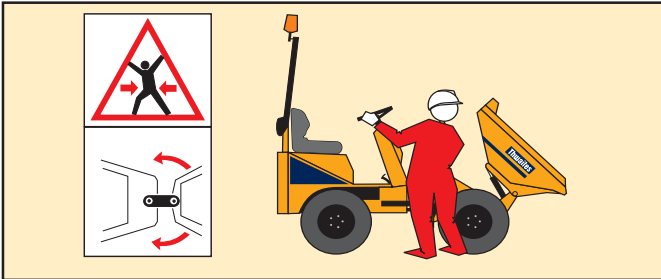

Before operating, sound the horn to warn people in the immediate area.

**CRUSH ZONE**

Stay clear of articulation area when the engine is running

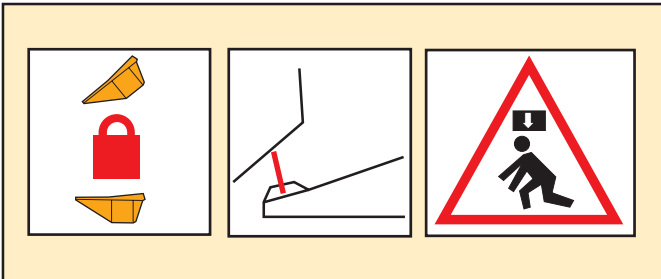

Never operate the machine's controls when standing on either side of machine

**WORKING UNDER A RAISED SKIP**

Lock skip and lift arm with safety props during maintenance.



Never work under an unpropped skip or lift arm.

Attention! Section*Correct and Incorrect Working Practices*

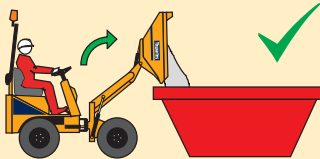
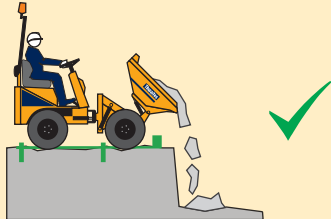
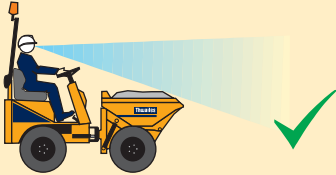
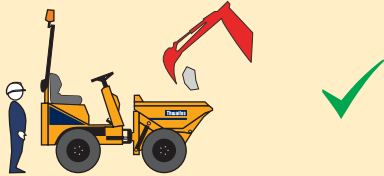
3**WARNING****HAZARDS OR UNSAFE PRACTICES WHICH COULD RESULT IN SEVERE PERSONAL INJURY OR DEATH****Thwaites****LOADING THE MACHINE****DO NOT** exceed the machine's rated capacity**DO NOT** load the skip with the lift arms in a raised positionSet transmission to **NEUTRAL**, turn engine **OFF**, disembark the machine and **STAND CLEAR**.

Clear debris from controls, floorplate, centre joint, steering ram, throttle pedal

Ensure **SAFE STABLE LOW** load, allowing for good visibility

Reduce payload if materials being carried are not free flowing

**UNLOADING**Use **STOPBOARDS** and **SUPPORT** walls on trenches**DO NOT** tip the skip if its load is sticking

Stop on level ground when unloading into a skip or raising skip arm.

Select neutral using **FNR** lever when raising or tipping skip – this will prevent the machine from moving*Attention! Section***3***Correct and Incorrect Working Practices*

3



WARNING

HAZARDS OR UNSAFE PRACTICES WHICH COULD RESULT IN SEVERE PERSONAL INJURY OR DEATH

Thwaites

DRIVING

| | | | | | |
|--|--|---|--|--|--|
| | | DO NOT drive with the skip in a raised or tipped position | | | NEVER dismount from a moving machine |
| | | DO NOT carry passengers | | | Avoid confined work areas - exhaust fumes and noise can be a hazard |
| | | Site hazards to avoid: adverse weather conditions; icy surfaces; people | | | DO NOT operate with a damaged ROPS frame or when folded in the down position |

*Not e: damaged ROPS frame must be replaced **NOT** repaired!*

Attention! Section

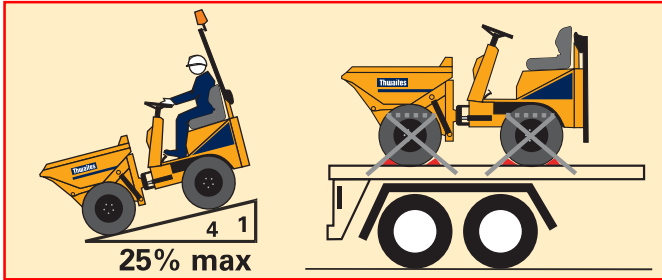

Correct and Incorrect Working Practices

3**WARNING****HAZARDS OR UNSAFE PRACTICES WHICH COULD RESULT IN SEVERE PERSONAL INJURY OR DEATH****Thwaites****TRANSPORTATION**

Reverse the machine slowly onto a suitable trailer.

**DO NOT** the machine forwards when loading on a ramp

- 1 Stop engine (automatic park brake applied).
- 2 Chock wheels (*to prevent movement*)
- 3 Engage chassis locking pin
- 4 Secure to trailer
- 5 Ensure legal load (*height/weight*)

Attention! Section*Correct and Incorrect Working Practices*

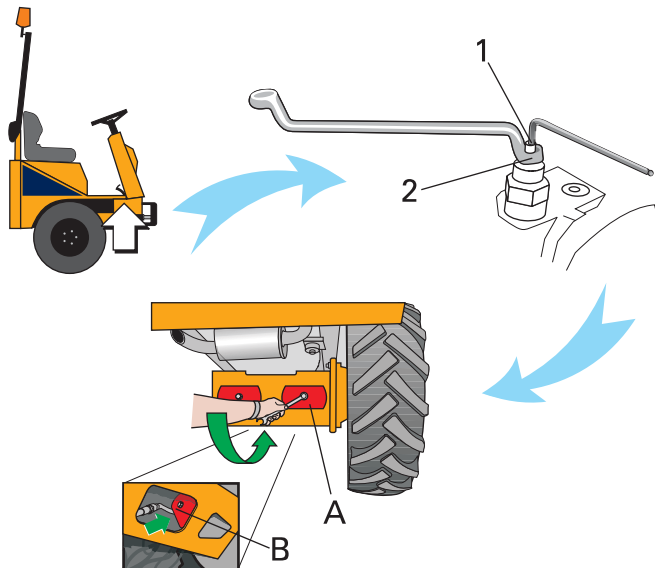
3 **CAUTION**HAZARDS OR UNSAFE PRACTICES WHICH **COULD** RESULT IN MINOR PERSONAL INJURY OR PRODUCT OR PROPERTY DAMAGE**Thwaites** **CAUTION**

When towing the vehicle:

- Do not exceed the maximum towing speed of 2 km/h.
- Do not exceed the towing distance of 1 km.

TOWING THE VEHICLE

In order to tow the vehicle, the hydrostatic drive on the engine must be bypassed, and the spring-loaded brakes at the two rear wheel motors must be disconnected.

Bypassing the hydrostatic drive

This is achieved by unscrewing two valves on the pump. One valve is beneath the footplate; the other is opposite this, underneath the pump.

To activate the hydrostatic transmission bypass:

- release lock nut (2);
- screw in grub screw (1) until flush with top of nut (2);
- tighten nut (2).

To re-activate the hydrostatic transmission:

- screw back item 1 to stop;
- screw back the nut.



Disconnect the spring-loaded brakes

- Chock wheels to prevent movement when brakes are disconnected
- dismantle the two extractors (A) attached at the rear axle box (This is achieved by unscrewing the hexagon bolts)
- remove the plastic plug in the centre of the wheel motor face.
- place the extractor on the wheel motor (B) and screw in the hexagon bolt removed earlier.
- Tighten bolt to 42 Nm until wheel removes freely.
- Replace extractors to re-activate spring-loaded brakes and replace plastic plug.

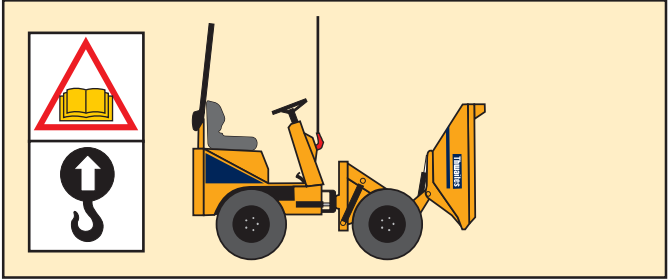
Attention! Section  Correct and Incorrect Working Practices



LIFTING USING A CRANE

-  Tip skip fully forward
-  Engage chassis locking pin
-  Lift using centre eye provided

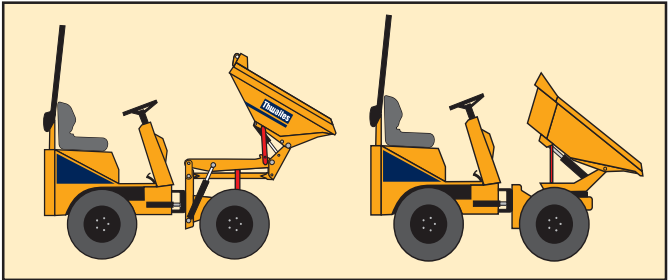

MAINTENANCE

-  Engage skip safety prop and/lift arm prop when working beneath the skip.



CAUTION

HAZARDS OR UNSAFE PRACTICES WHICH **COULD** RESULT IN MINOR PERSONAL INJURY OR PRODUCT OR PROPERTY DAMAGE

Thwaites

ATTENDING TO A ROLLED-OVER MACHINE

Failure to adhere to the safe working practices described in this manual could lead to the machine rolling onto its side. In the event of the machine rolling onto its side, the following steps should be taken:



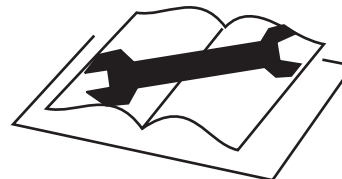

1. Turn off engine. Use either the emergency stop button or the ignition switch;
2. Protect against fire. Fuel or oil leaks may cause combustion;
3. Return machine to an upright position using suitable lifting equipment;
4. Refer to service manual for instructions on how to safely restart engine.

Failure to follow this procedure could result in serious damage to the engine. This will invalidate your warranty.



4 Troubleshooting

Thwaites

| Problem | Reason | Solution |
|--|--|---|
| Engine will not start | Isolator switch OFF FNR lever not in neutral Emergency stop button pressed down Circuit breaker tripped Battery voltage too low Faulty fuel supply Electrical stop on fuel pump defective. | Switch on Shift to neutral Release button upwards Reset (Push to reset) Check battery and connections Check fuel level and connections Check connections |
| Engine starts and stops | Blocked fuel or air filter Air in fuel system | Replace fuel or air filter Check fuel line connections |
| Black engine smoke | Air filter clogged (Indicator red). Fuel system defect Wrong fuel | Replace or clean air filter Contact Thwaites dealer Replace fuel and filter |
|  ● Engine oil pressure  ● High engine temperature  ● Irregular alternator  ● Automatic park brake remains applied | Low oil level Radiator choked Low coolant level Defective or loose alternator belt Forward/reverse selected within 2 seconds of engine start | Top up engine oil Clean radiator Top up coolant Adjust, or, if necessary, replace the alternator belt Select neutral and wait 2 seconds before re-selecting forward/reverse |
| Warning buzzer sounds | Starting Machine with FNR lever in forward/reverse Emergency stop button pressed down LED warning light on | Shift to neutral Release button upwards Turn off ignition and investigate fault |

Always investigate panel warning lights and tripped circuit breakers and blown maxi fuse

4 Data Chart - Hi-tip model

Thwaites

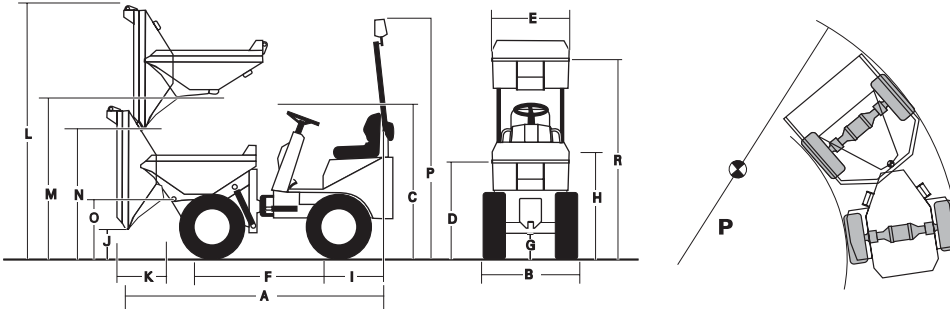



| Dimensions (mm) | 1T | Weight (Kg) | 1T | Noise |
|---|-------------|--|----------|-----------------|
| A. Length (max) | 3032 | Unladen | | Airbourne (10m) |
| B. Width | 1115 (982*) | Front axle | 440 | |
| C. Height (ROPS folded) | 1822 | Rear axle | 780 | |
| D. Skip lip height | 1155 | Total | 1220 | Operator |
| E. Skip width | 982 | Laden (including driver at 75 kg) | | |
| F. Wheelbase | 1500 | Rated payload | 1000 | |
| G. Ground clearance | 274 | Front axle | 1490 | |
| H. Skip load height | 1262 | Rear axle | 805 | |
| I. Axle to rear | 654 | Total | 2295 | |
| J. Tipping ground clearance | 346 | Tyre Pressure | | |
| K. Tipping tyre clearance | 505 | Bar (psi) Front | 3.0 (44) | |
| L. Max height tipped (raised skip) | 3005 | Rear | 3.0 (44) | |
| M. Skip over height (raised skip) | 1913 | | | |
| N. Tipping ground clearance (raised skip) | 1573 | | | |
| O. Skip over height | 720 | | | |
| R. Skip lip height (raised skip) | 2370 | | | |
| P. Height (ROPS & Beacon - max) | 2860 | | | |
| Q. Tyre clearance diameter | 5.45m | | | |
| *with optional narrow tyres | | | | |

Not e: pressures shown are for bot h st d 10/75 x 15.3 & optional 7.00 x 12 tyres

4 Data Chart – Powerswivel model

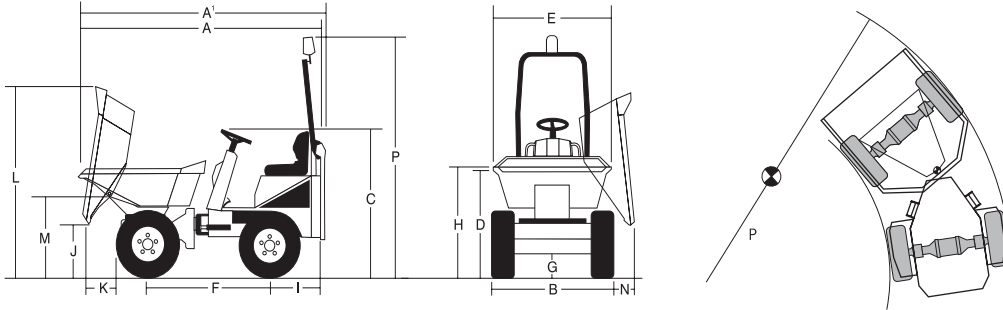
Thwaites



| Dimensions (mm) | 1T | Weight (Kg) | 1T | Noise |
|---------------------------------------|--------|--|----------|---|
| A. Length (ROPS raised) | 3062 | Unladen | | Airbourne (10m) |
| A'. Length (ROPS folded) | 3222 | Front axle | 465 |  |
| B. Width | 1195 | Rear axle | 760 | |
| C. Height (ROPS folded) | 1773 | Total | 1225 | Operator |
| D. Skip lip height | 1204 | Laden (including driver at 75 kg) | |  |
| E. Skip width | 1151 | Rated payload | 1000 | |
| F. Wheelbase | 1500 | Front axle | 1475 | |
| G. Ground clearance | 274 | Rear axle | 825 | |
| H. Skip load height | 1256 | Total | 2300 | |
| I. Axle to rear | 654 | Tyre Pressure | | |
| J. Tipping ground clearance | 642 | Bar (psi) Front | 3.0 (44) | |
| K. Tipping tyre clearance | 461 | Rear | 3.0 (44) | |
| L. Max height tipped | 2244 | | | |
| M. Skip over height | 901 | | | |
| N. Tipping side clearance | 154 | | | |
| P. Height (ROPS & Beacon - max) | 2860 | | | |
| Q. Tyre clearance diameter | 5.55 m | | | |

Note: pressures shown are for both std 10/75 x 15.3 & optional 7.00 x 12 tyres

4 Daily/Weekly Checks - Hi-tip model

Thwaites

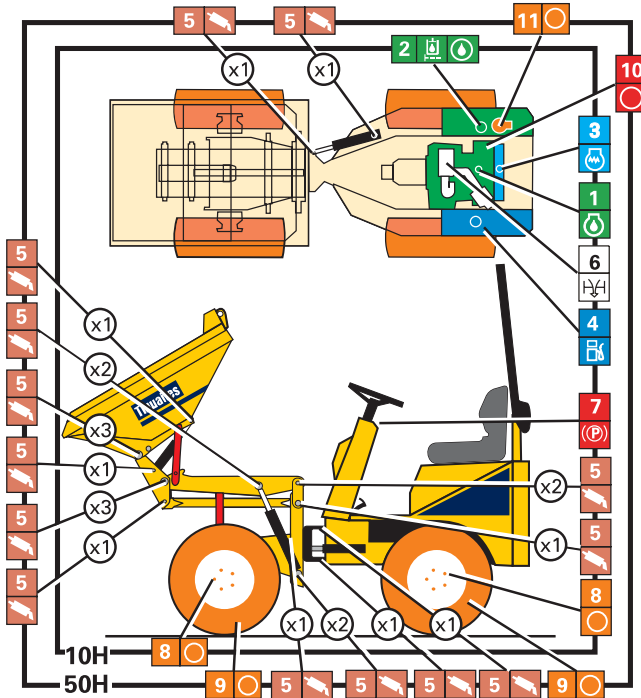

| | | | |
|--|-------------------------|----|-----------------------------------|
| | ENGINE OIL | 1 | BP Vanellus C5 Global 15W 40 |
| | TRANSMISSION OIL | 2 | BP Bartran HV 46 |
| | HYDRAULIC OIL | 2 | BP Bartran HV 46 |
| | COOLANT | 3 | H ₂ O + 50% Antifreeze |
| | FUEL | 4 | Diesel |
| | GREASE | 5 | Fill all 21 points |
| | AIR CLEANER | 6 | Check indicator |
| | BRAKES | 7 | Release stop button |
| | WHEEL NUTS | 8 | 170 Nm (125 lb f ft) |
| | TYRE PRESSURE | 9 | 3.0 Bar (44 psi) |
| | FAN BELT | 10 | Check condition/tension |
| | HYDRAULIC FILTER | 11 | Check indicator |

This machine must be serviced after first 50 hours

Normal service intervals:

250 hours 500 hours 1000 hours 2000 hours

Contact local Thwaites Distributor for details or www.thwaitesdumpers.co.uk

4 Daily/Weekly Checks – Powerswivel model

Thwaites

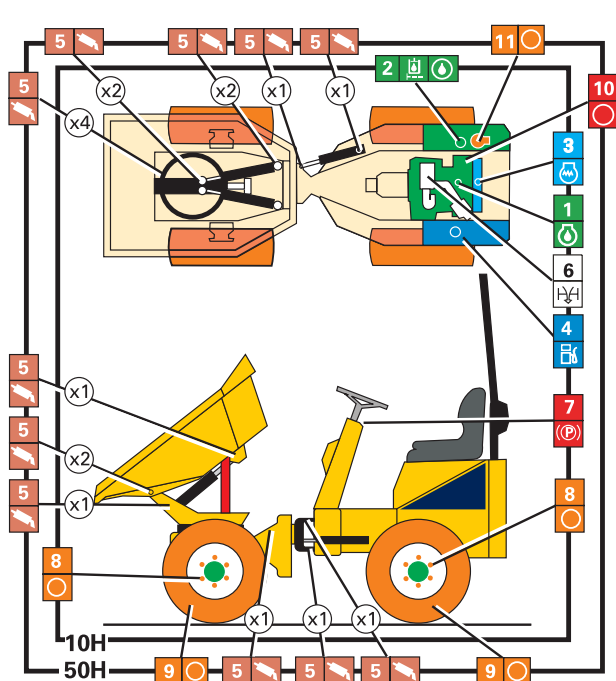

| | | | |
|--|-------------------------|----|-----------------------------------|
| | ENGINE OIL | 1 | BP Vanellus C5 Global 15W 40 |
| | TRANSMISSION OIL | 2 | BP Bartran HV 46 |
| | HYDRAULIC OIL | 2 | BP Bartran HV 46 |
| | COOLANT | 3 | H ₂ O + 50% Antifreeze |
| | FUEL | 4 | Diesel |
| | GREASE | 5 | Fill all 17 points |
| | AIR CLEANER | 6 | Check indicator |
| | BRAKES | 7 | Release stop button |
| | WHEEL NUTS | 8 | 170 Nm (125 lb f ft) |
| | TYRE PRESSURE | 9 | 3.0 Bar (44 psi) |
| | FAN BELT | 10 | Check condition/tension |
| | HYDRAULIC FILTER | 11 | Check indicator |

This machine must be serviced after first 50 hours

Normal service intervals:

250 hours 500 hours 1000 hours 2000 hours

Contact local Thwaites Distributor for details or www.thwaitesdumpers.co.uk